

TABLE OF CONTENTS

| | |
|---|---------|
| INTRODUCTION OF THE OWNER'S MANUAL | 1 |
| 1. HANDLING PRECAUTIONS | 1 |
| 2. PREVENTION OF COUNTERFEITING AND CONVERSION | 2 |
| 3. PRECAUTIONS CONCERNING THE PLACE OF INSTALLATION ... | 3 |
| 4. EXTERIOR VIEW OF GAME ① | 4 |
| EXTERIOR VIEW OF GAME ② | 5 |
| 5. ADJUSTMENT OF THE SERVICE SWITCH | 6 |
| 6. DIP SWITCH SETTING | 7 |
| 7. SETTING THE DIFFICULTY LEVEL FOR THE "UPRIGHT" TYPE | 8 |
| 8. HANDLE'S CENTERING ADJUSTMENT | 9 |
| 9. ADJUSTING THE ACCELERATOR/BRAKE | 10 |
| 10. EPROM LOCATION | 11 · 12 |
| 11. SELF-TESTING | 13~19 |
| 12. REMOVING THE HANDLE COVER | 20 |
| 13. REMOVING THE HANDLE UNIT | 21 |
| 14. REMOVING THE WINDOW MASK | 22 |
| 15. REPLACING THE ACCELERATOR/BRAKE VOLUME CONTROLS ... | 23 |
| 16. REPLACING THE ACCELERATOR/BRAKE WIRES | 24 |
| 17. PARTS LIST | 25~39 |
| 18. SCHEMATIC DIAGRAM | 40 |

SPECIFICATIONS

| | |
|--------------------|---|
| INSTALLATION SPACE | : 24.8 in. (63 cm) × 38.6 in. (98 cm) |
| HEIGHT | : 72.8 in. (185 cm) |
| POWER | : 185 W |

NOTE

o Descriptions herein contained may be subject to improvement changes without notice.

INTRODUCTION OF THE OWNER'S MANUAL

SEGA ENTERPRISES, LTD., supported by its high electronic technology of LSIS, microprocessors, etc. and a wealth of experience, has for more than 30 years been supplying various innovative and popular game machines to the world market. This OWNER'S manual is intended to provide detailed comments together with all the necessary information covering the operation in general of electronic assemblies, electromechanicals, servicing control, spare parts, etc. as regards the HANG·ON, a new SEGA product. The manual is intended for those who have knowledge of electricity and technical expertise especially in ICs, CRTs, microprocessors, etc. Carefully read so as to acquire sufficient knowledge before working on the machine. Should there be a malfunction, non-technical personnel should under no circumstance touch the interior system.

1. HANDLING PRECAUTIONS

When installing or inspecting, be very careful of the following points and pay attention to ensure that the player can enjoy the game safely.

- o Be sure to turn the power off before working on the machine.
- o To insert or pull out the plug quickly is dangerous.
- o It is necessary to make sure that the power cord or the grounding wire is not exposed on the road, etc. in a manner so as to be dangerous. Make sure that grounding connections are made safely at the position where so specified.
- o Do not use any fuse that does not meet the specified rating.
- o Make complete connections for the IC board and other connectors. Insufficient insertion is very dangerous.

Also, for the IC board circuit inspections, only the logic tone is allowed. The use of a tester is not permitted so be careful in this regard. After confirming that there are no irregularities, turn the power ON.

2. PREVENTION OF COUNTERFEITING AND CONVERSION

LABELLING

To prevent counterfeits and conversions, the following labels are put on all the SEGA products. When handling such goods, be sure to confirm the labels. They are used to prevent illegal acts such as the unauthorized copying of the products and the printed circuit boards thereof or carrying on business by manufacturing similar merchandise or by converting, selling or using such products or printed circuit boards.

ORIGINAL SEAL

The following seal is put on the machines manufactured by SEGA.



LICENCE SEAL

The following seal is put on the kits, such as the printed circuit boards, of SEGA products.

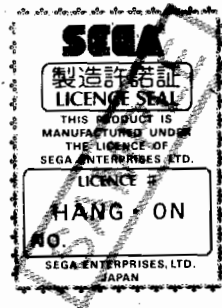

COPYRIGHT NOTICE

This SEGA product has the copyright notice as follows:

© SEGA 1985

This signifies that this work was disclosed in 1985 and is the property of SEGA ENTERPRISES, LTD.

3. PRECAUTIONS CONCERNING THE PLACE OF INSTALLATION

The HANG-ON is an indoor game machine. Absolutely do not install it outside. Even indoors, avoid installing in places mentioned below so as to ensure proper usage:

- o Places subject to rain or water leakage, or condensation due to humidity.
- o In the proximity of an indoor swimming pool and/or shower.
- o Places subject to direct sunlight.
- o Places subject to heat sources from heating units, etc., or hot air.
- o Vicinity of highly inflammable/volatile chemicals or hazardous matter.
- o Sloped surfaces.
- o Vicinity of anti-disaster facilities such as fire exits and fire extinguishers.
- o Places subject to any type of violent impact.
- o Dusty places.

4. EXTERIOR VIEW OF GAME ①

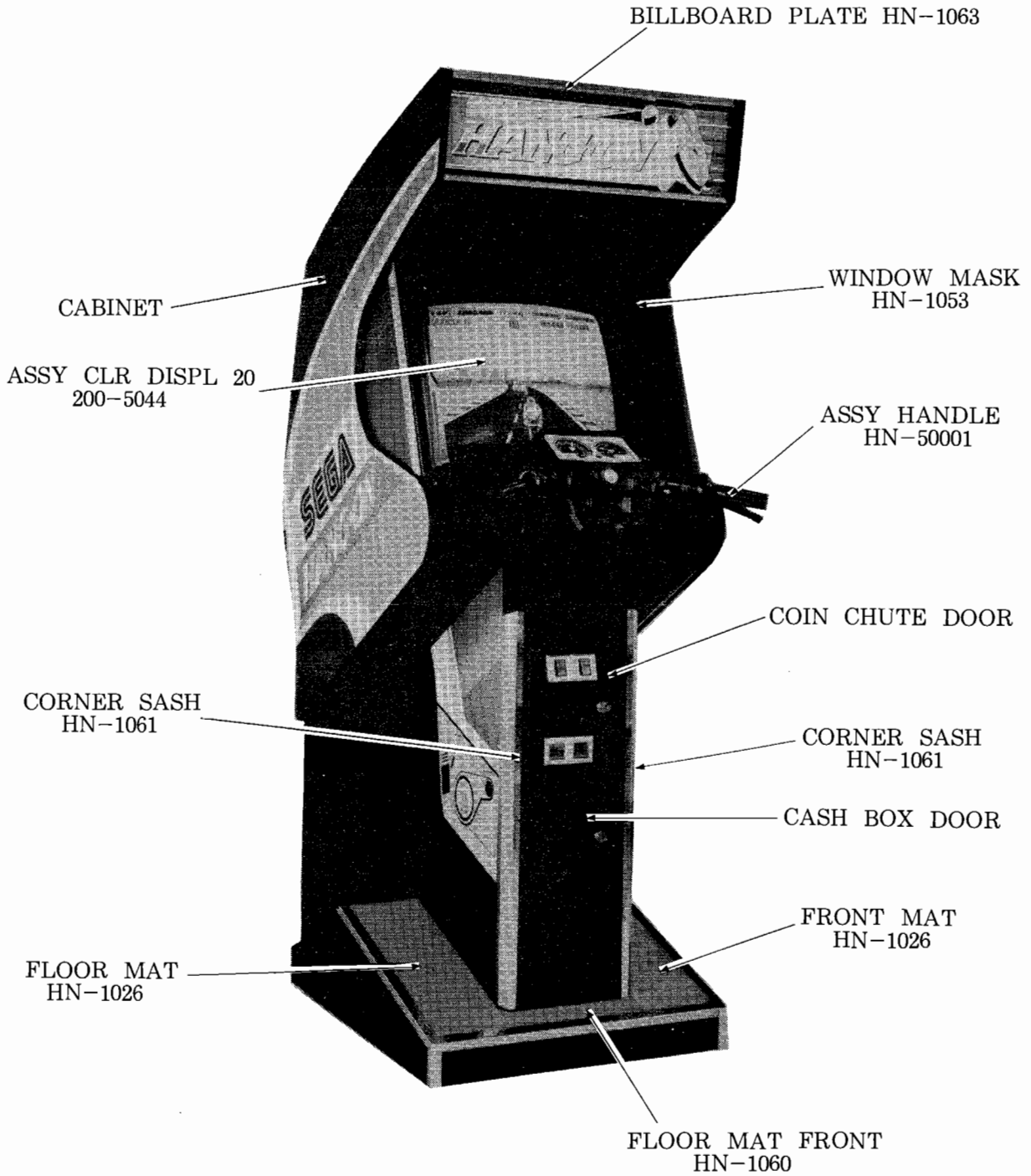

4. EXTERIOR VIEW OF GAME ②

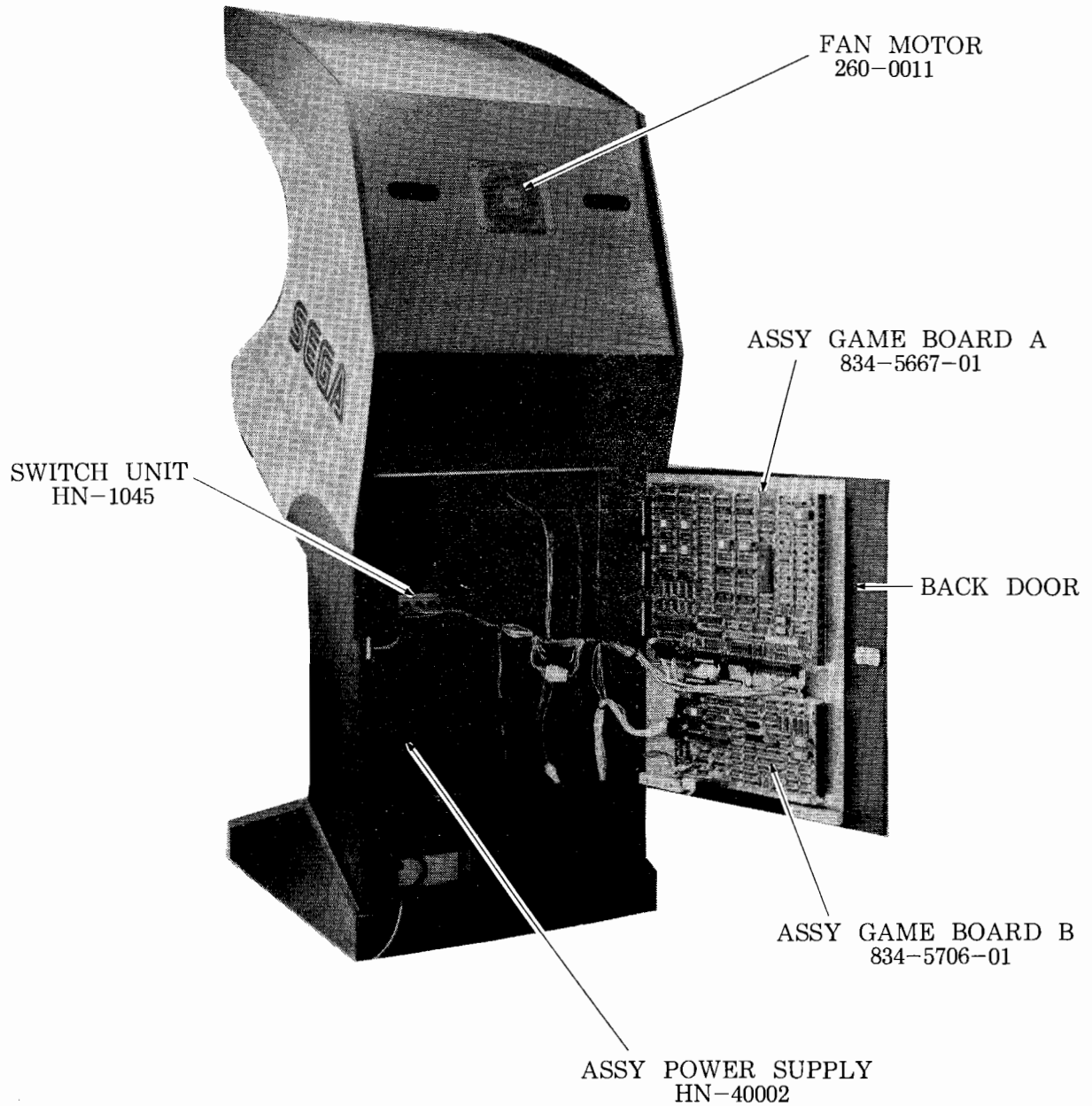

5. ADJUSTMENT OF THE SERVICE SWITCH

The layout as shown below can be viewed by opening the coin chute door.

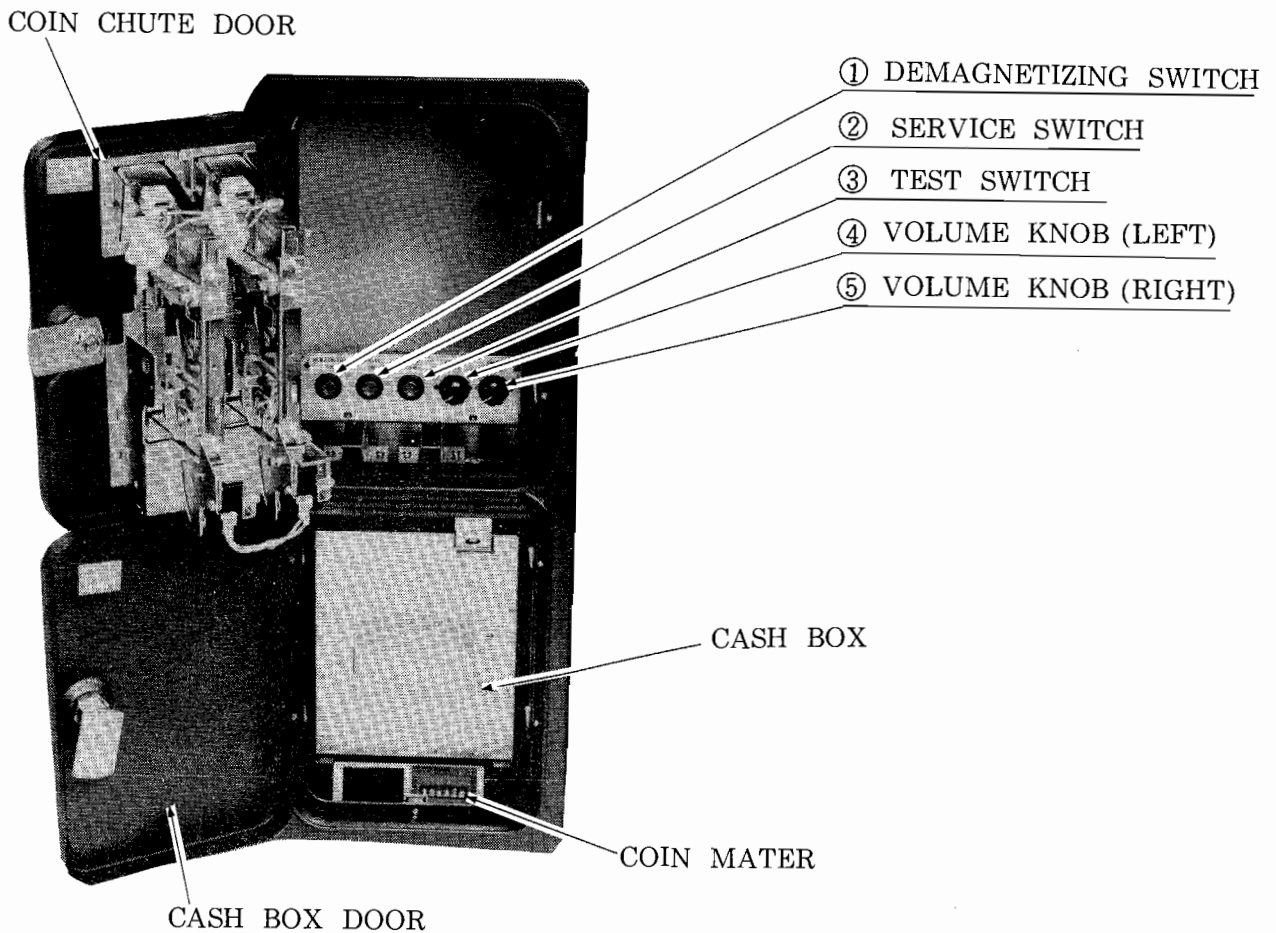

OPERATING INSTRUCTIONS

- ① DEMAGNETIZING SWITCH.....Used for removing the on-screen color unevenness.
- ② SERVICE SWITCH.....Used for the purpose of servicing and increasing the credits without registering on the meter (this allows you to check the game).
- ③ TEST SWITCH.....For operating this switch, see 13 .
SELF-TESTING.
- ④⑤ VOLUME ADJUSTMENT.....The volume of the right/left speakers is separately adjusted (pay attention to the right/left volume balance).

6. DIP SWITCH SETTING

Game Price Settings

| OPTION | DIP SW #1 | | | | | | | |
|-------------------|------------|-----|-----|-----|------------|-----|-----|-----|
| | 1 | 2 | 3 | 4 | 5 | 6 | 7 | 8 |
| 1 COIN 1 CREDIT | OFF | OFF | OFF | OFF | OFF | OFF | OFF | OFF |
| 1 COIN 2 CREDITS | ON | OFF | OFF | OFF | ON | OFF | OFF | OFF |
| 1 COIN 3 CREDITS | OFF | ON | OFF | OFF | OFF | ON | OFF | OFF |
| 1 COIN 4 CREDITS | ON | ON | OFF | OFF | ON | ON | OFF | OFF |
| 1 COIN 5 CREDITS | OFF | OFF | ON | OFF | OFF | OFF | ON | OFF |
| 1 COIN 6 CREDITS | ON | OFF | ON | OFF | ON | OFF | ON | OFF |
| 2 COINS 1 CREDIT | OFF | ON | ON | OFF | OFF | ON | ON | OFF |
| 3 COINS 1 CREDIT | ON | ON | ON | OFF | ON | ON | ON | OFF |
| 4 COINS 1 CREDIT | OFF | OFF | OFF | ON | OFF | OFF | OFF | ON |
| 2 COINS 3 CREDITS | ON | OFF | OFF | ON | ON | OFF | OFF | ON |
| 2 COINS 1 CREDIT | | | | | | | | |
| 4 COINS 2 CREDITS | OFF | ON | OFF | ON | OFF | ON | OFF | ON |
| 5 COINS 3 CREDITS | | | | | | | | |
| 6 COINS 4 CREDITS | | | | | | | | |
| 2 COINS 1 CREDIT | ON | ON | OFF | ON | ON | ON | OFF | ON |
| 4 COINS 3 CREDITS | | | | | | | | |
| 1 COIN 1 CREDIT | | | | | | | | |
| 2 COINS 2 CREDITS | OFF | OFF | ON | ON | OFF | OFF | ON | ON |
| 3 COINS 3 CREDITS | | | | | | | | |
| 4 COINS 4 CREDITS | | | | | | | | |
| 5 COINS 6 CREDITS | | | | | | | | |
| 1 COIN 1 CREDIT | | | | | | | | |
| 2 COINS 2 CREDITS | ON | OFF | ON | ON | ON | OFF | ON | ON |
| 3 COINS 3 CREDITS | | | | | | | | |
| 4 COINS 5 CREDITS | | | | | | | | |
| 1 COIN 1 CREDIT | OFF | ON | ON | ON | OFF | ON | ON | ON |
| 2 COINS 3 CREDITS | | | | | | | | |
| 1 COIN 1 CREDIT | ON | ON | ON | ON | ON | ON | ON | ON |
| | COIN SW #1 | | | | COIN SW #2 | | | |

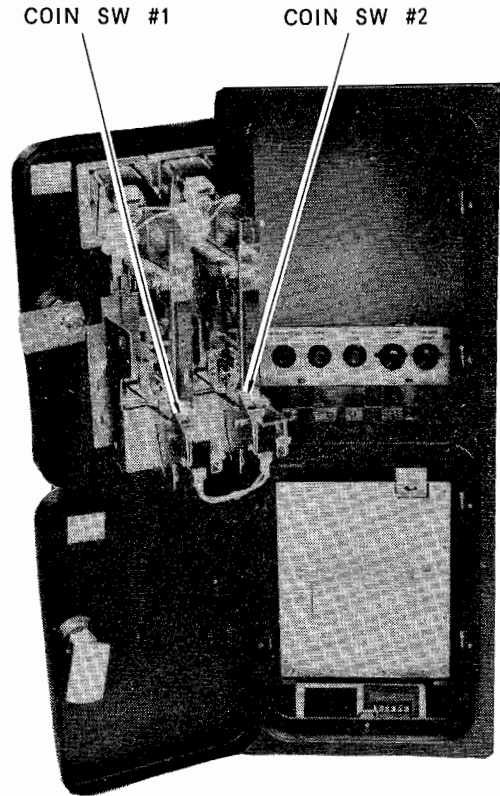

Game Option Settings

| OPTION | DIP SW #2 | | | | | | | |
|---------------|-----------|-----|-----|-----|-----|-----|---|-----|
| | 1 | 2 | 3 | 4 | 5 | 6 | 7 | 8 |
| ADVERTISE OFF | OFF | | | | | | | |
| SOUND ON | ON | | | | | | | |
| GAME MEDIUM | | OFF | OFF | | | | | |
| EASY | | ON | OFF | | | | | |
| HARD | | OFF | ON | | | | | |
| HARDEST | | ON | ON | | | | | |
| TIME EASY | | | | OFF | OFF | | | |
| MEDIUM | | | | ON | OFF | | | |
| HARD | | | | OFF | ON | | | |
| HARDEST | | | | ON | ON | | | |
| PLAY MUSIC ON | | | | | | OFF | | |
| OFF | | | | | | ON | | |
| | | | | | | | | OFF |

DIP SW #1 DIP SW #2

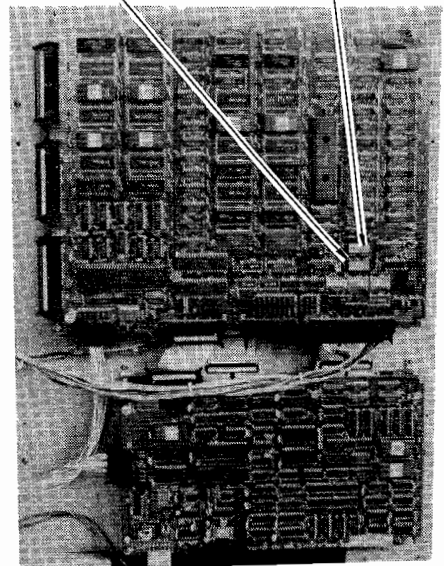

DIP SWITCH

- o For details concerning the difficulty level setting, see page 8 .

7. SETTING THE DIFFICULTY LEVEL FOR THE " UPRIGHT " TYPE

For the UPRIGHT type HANG-ON machine, the difficultness of the game can be set for 4 different levels by adjusting ①, the other cars' appearance frequency and ②, the game time, using DIP SWITCH No. 2 on the PC (printed circuit) board. Depending on the skills of the players, appropriate difficulty levels can be set as applicable. When shipping the machine, the difficulty levels for both the above-mentioned ① and ② are set for the * mark level.

① Other cars' appearance frequency (set by DIP SWITCHES 2 & 3)

| SWITCH NO. | | The other cars' appearance frequency | Difficulty level |
|------------|-----|--------------------------------------|------------------|
| 3 | 2 | | |
| OFF | OFF | ————— | MEDIUM |
| OFF | ON | 30% lower than MEDIUM | EASY |
| ON | OFF | 40% higher than MEDIUM | HARD |
| ON | ON | 80% higher than MEDIUM | HARDEST |

*←When shipping

② Game time adjustment (set by DIP SWITCH 4 & 5)

| SWITCH NO. | | Game time (seconds) per stage | | | | | Difficulty level |
|------------|-----|-------------------------------|----|----|----|----|------------------|
| 5 | 4 | 1 | 2 | 3 | 4 | 5 | |
| OFF | OFF | 75 | 60 | 55 | 55 | 50 | EASY |
| OFF | ON | 70 | 60 | 60 | 55 | 55 | MEDIUM |
| ON | OFF | 65 | 60 | 55 | 60 | 55 | HARD |
| ON | ON | 60 | 60 | 60 | 60 | 55 | HARDEST |

*←When shipping

DETAILED EXAMPLES

| DIP SW NO. | | | | Difficulty level |
|------------|-----|-----|-----|------------------|
| 5 | 4 | 3 | 2 | |
| OFF | OFF | OFF | ON | 1 |
| OFF | ON | OFF | ON | 2 |
| ON | OFF | OFF | ON | 3 |
| ON | ON | OFF | ON | 4 |
| OFF | OFF | OFF | OFF | 5 |
| OFF | ON | OFF | OFF | 6 |
| ON | OFF | OFF | OFF | 7 |
| ON | ON | OFF | OFF | 8 |
| OFF | OFF | ON | OFF | 9 |
| OFF | ON | ON | OFF | 10 |
| ON | OFF | ON | OFF | 11 |
| ON | ON | ON | OFF | 12 |
| OFF | OFF | ON | ON | 13 |
| OFF | ON | ON | ON | 14 |
| ON | OFF | ON | ON | 15 |
| ON | ON | ON | ON | 16 |

* When shipping

8. HANDLE'S CENTERING ADJUSTMENT

- o When the HANDLE is in a stationary position, display the following on the screen in the SELF-TEST mode:
- o At this time, if the variable value becomes 80H, it is considered normal.

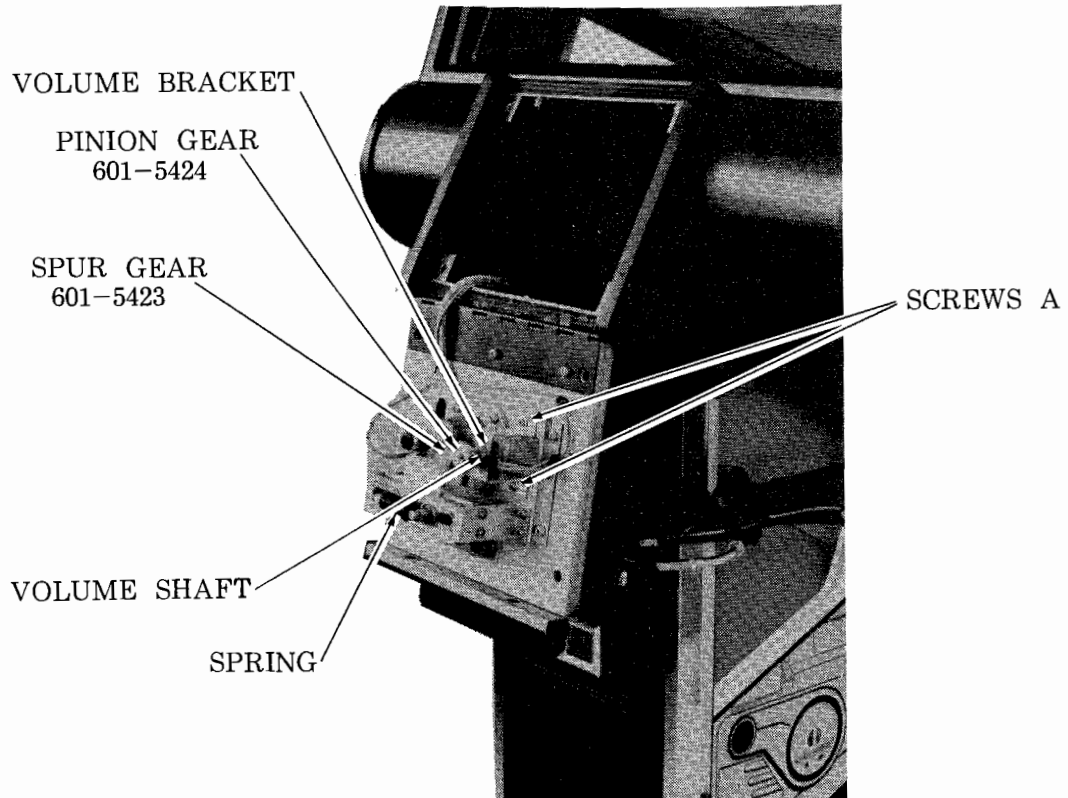

ADJUSTING PROCEDURE

- ① The VOLUME BRACKET can be moved in the right and the left directions by releasing 2 SCREWS A which fasten it.
- ② Move the VOLUME BRACKET to the right to disengage the PINION GEAR and the SPUR GEAR. At this time, make adjustments by turning the VOLUME SHAFT in a manner so that the variable value falls within the allowable range.
- ③ In the case where fine adjustments are necessary, slightly release the VOLUME BRACKET and then turn it in the applicable direction.

| DIAGNOSTIC INPUT TEST | | |
|--------------------------|-----------|-------|
| COIN # 1 | START | |
| COIN # 2 | SERVICE | |
| FOOT SW R | FOOT SW L | |
| ANGLE | DATA | 80H ← |
| ACCEL | DATA | 00H |
| BRAKE | DATA | 00H |

VARIABLES

9. ADJUSTING THE ACCELERATOR / BRAKE

- o After replacing the ACCELERATOR/BRAKE WIRES, carry out the following test:
- o Display the following on the screen in the SELF-TEST MODE (see page 15).

ACCELERATOR

- o When the ACCELERATOR is returned to its original OFF position, make adjustment in a manner so that the variable value becomes OH.
Allowable range: OH-4H
- o Make adjustment of the wire's length by using NUT C (see page 24).

| DIAGNOSTIC INPUT TEST | | |
|--------------------------|------|-----------|
| COIN # 1 | | START |
| COIN # 2 | | SERVICE |
| FOOT SW R | | FOOT SW L |
| ANGLE | DATA | 80H |
| ACCEL | DATA | 00H |
| BRAKE | DATA | 00H |

← VARIABLE VALUE

BRAKE

When the ACCELERATOR is returned to its original OFF position, make sure that the VARIABLE VALUE becomes OH.

Allowable range: OH-4H

- o Adjust the wire's length by using NUT C (see page 24).

| DIAGNOSTIC INPUT TEST | | |
|--------------------------|------|-----------|
| COIN # 1 | | START |
| COIN # 2 | | SERVICE |
| FOOT SW R | | FOOT SW L |
| ANGLE | DATA | 80H |
| ACCEL | DATA | 00H |
| BRAKE | DATA | 00H |

← VARIABLE VALUE

- o When the ACCELERATOR/BRAKE is moved the maximum distance, the PINION GEAR (see page 24). turns approximately 180 degrees.

10. EPROM LOCATION

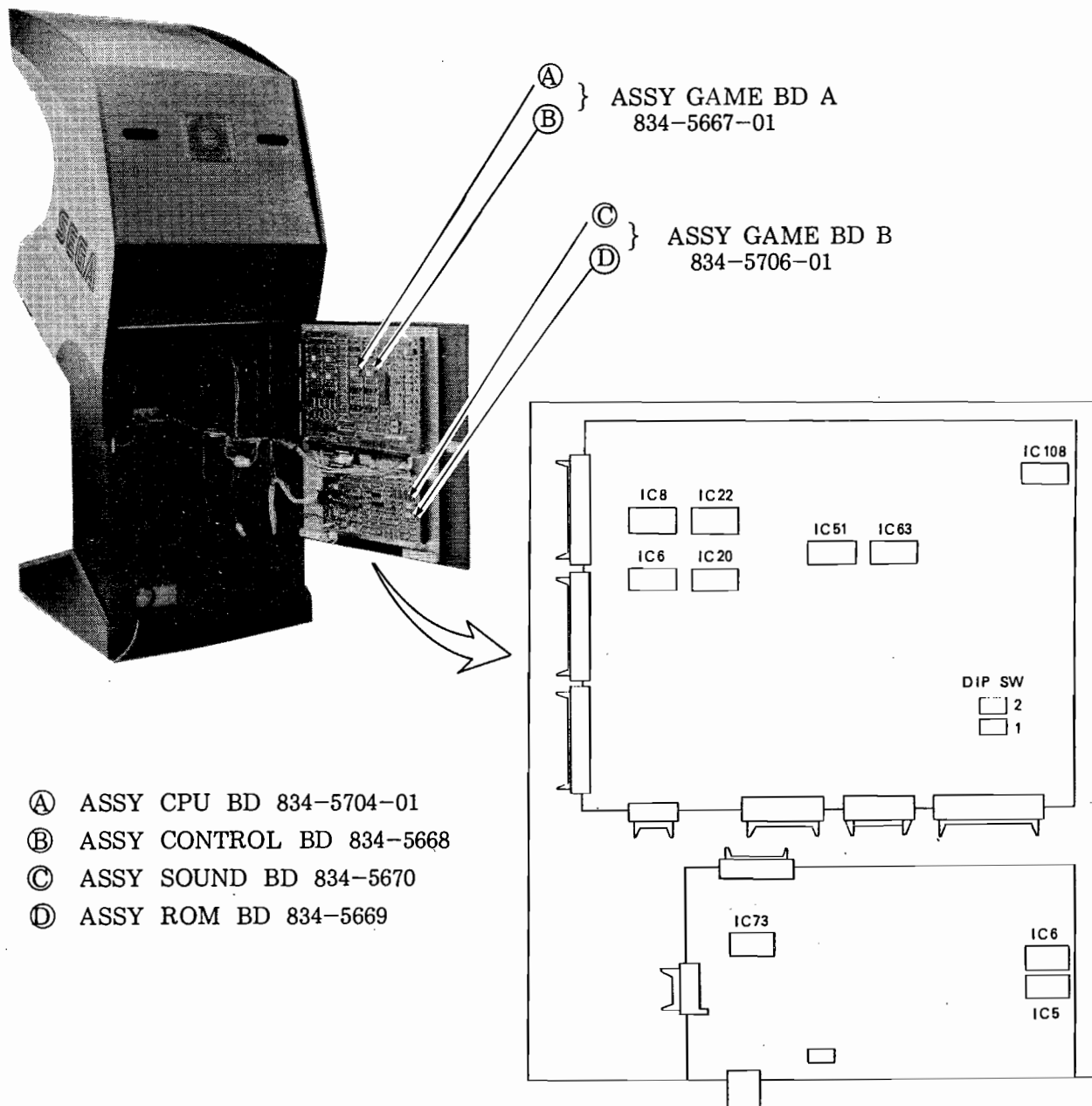

- Ⓐ ASSY CPU BD 834-5704-01
- Ⓑ ASSY CONTROL BD 834-5668
- Ⓒ ASSY SOUND BD 834-5670
- Ⓓ ASSY ROM BD 834-5669

Ⓐ ASSY CPU BD 834-5704-01

| IC LOCATIONS | NUMBERS | MAIN FUNCTIONS |
|--------------|-----------|----------------|
| 1 IC 6 | EPR-6915A | MAIN PROGRAM |
| 2 IC 8 | EPR-6916A | MAIN PROGRAM |
| 3 IC 20 | EPR-6917A | MAIN PROGRAM |
| 4 IC 22 | EPR-6918A | MAIN PROGRAM |
| 5 IC 51 | EPR-6919 | SUB PROGRAM |
| 6 IC 63 | EPR-6920 | SUB PROGRAM |
| 7 IC 108 | EPR-6840 | ROAD CHARACTER |

Ⓑ ASSY CONTROL BD 834-5668

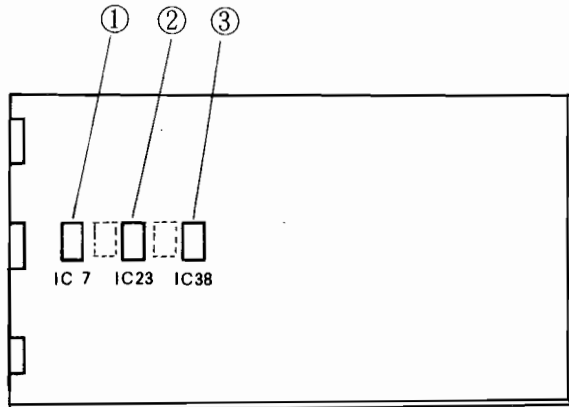

| IC locations | Numbers | Main functions |
|--------------|---------|----------------|
| 1 | IC 7 | EPR-6843 |
| 2 | IC 23 | EPR-6842 |
| 3 | IC 38 | EPR-6841 |

Letters & characters

Ⓒ ASSY SOUND BD 834-5670

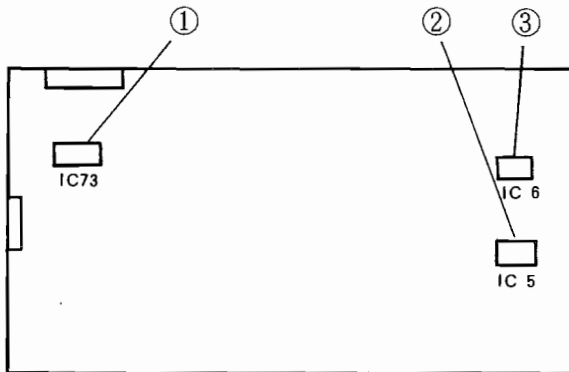

| IC locations | Numbers | Main functions |
|--------------|---------|----------------|
| 1 | IC 73 | EPR-6833 |
| 2 | IC 5 | EPR-6831 |
| 3 | IC 6 | EPR-6832 |

Driving and other sounds

Ⓓ ASSY ROM BD 834-5669

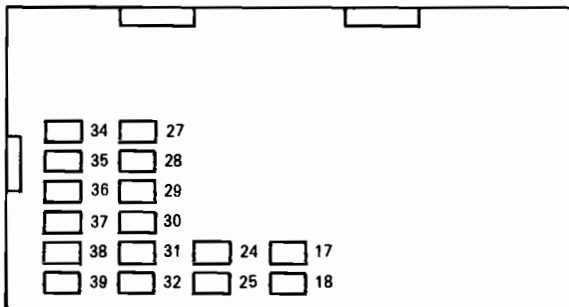

| IC locations | Numbers | Main functions |
|--------------|---------|----------------|
| 1 | IC 27 | EPR-6819 |
| 2 | IC 34 | EPR-6820 |
| 3 | IC 28 | EPR-6821 |
| 4 | IC 35 | EPR-6822 |
| 5 | IC 29 | EPR-6823 |
| 6 | IC 36 | EPR-6824 |
| 7 | IC 30 | EPR-6825 |
| 8 | IC 37 | EPR-6826 |
| 9 | IC 31 | EPR-6827 |
| 10 | IC 38 | EPR-6828 |
| 11 | IC 32 | EPR-6829 |
| 12 | IC 39 | EPR-6830 |
| 13 | IC 18 | EPR-6845 |
| 14 | IC 25 | EPR-6846 |

Scenery figures

11. SELF-TESTING

The main purpose of these tests are to check the operations of the game boards, to find the defects if any, to adjust the monitor colors properly, and to make sure the sounds are produced satisfactorily. It is also performed to indicate the assignments of the dip switches, check bookkeeping functions, etc.

KIND OF TESTS

- 1) Memory Test: To check the EPROM programs and the map area of the RAMs.
- 2) Input Test: To check the machine's inclining angle and to test the operation of the accelerator, brake, coin switches, etc.
- 3) Output Test: To test the operation of the start lamp.
- 4) Sound Test: To check the quality of the sounds produced by the PCB and the video disc, and adjust the balance of the speakers.
- 5) CRT Test: To check if the colors on the monitor are displayed correctly, and to adjust the linearity.
- 6) Dip Switch
Assignment: To indicate each dip switch assignment.
- 7) Bookkeeping: To indicate information data on average score and average play time, etc.

1. TEST OPERATION

- (1) Push the test switch and Fig. 1 will be shown on the screen.
- (2) Select CONTINUE or INDIVIDUAL by using the START button.

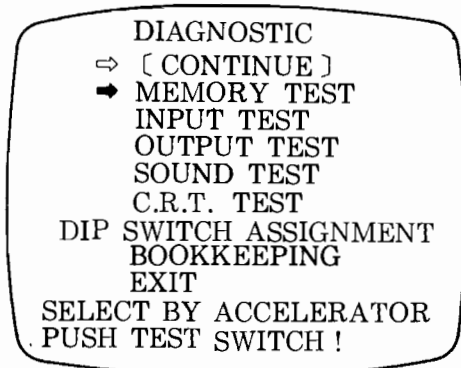

FIG. 1

- (3) Move the accelerator to bring the arrow to the desired position.

SELECT BY ACCELERATOR PUSH TEST SWITCH
(Select the desired test item by using the accelerator and push the test switch button.)

[CONTINUE]:

- o Bring the arrow sign (by operating the control lever) to CONTINUE first, and move it to one of the tests to start. Push the TEST button, and the tests will be performed in order, one by one, starting from the test where the arrow was originally set to the EXIT.

- o If the START button is pushed when the arrow is at CONTINUE, it will change to INDIVIDUAL. Pushing it again returns it to CONTINUE.

[INDIVIDUAL]:

- o If the arrow is at INDIVIDUAL first and brought to a certain test which you want to conduct, only that test is performed by pushing the TEST button.

(4) When each test is finished in the case of CONTINUE, push the TEST button, and it will automatically go into the following test. If the TEST button is pushed in the case of INDIVIDUAL, FIG. 1 is shown. If you want to end the test mode at this time, bring the arrow to EXIT and push the TEST button, and it will return to the ADVERTISEMENT mode.

2. TEST ITEMS

(1) Memory Test:

```

DIAGNOSTIC
MEMORY TEST

**   ROMS TEST   **
IC 8 GOOD IC 6 GOOD IC 51 GOOD
IC 22 GOOD IC 20 GOOD IC 63 GOOD

**   RAMS TEST   **
IC 54 GOOD IC 74 GOOD IC 90 GOOD
IC 66 GOOD IC 75 GOOD IC 104 GOOD
IC 73 GOOD IC 2 GOOD IC 10 GOOD
IC 52 GOOD IC 1 GOOD IC 24 GOOD
IC 46 GOOD IC 58 GOOD
  
```

Indication of "GOOD" following the IC No. means the IC is all right. Push the TEST button to proceed to the following test item.

(2) Input Test

```

DIAGNOSTICS
INPUT TEST

COIN # 1      START
COIN # 2      SERVICE
FOOT SW R    FOOT SW L
ANGLE  DATA  80H
ACCEL  DATA  00H
BRAKE  DATA  00H
  
```

→ Applicable only for the RIDE ON type (not the UPRIGHT type).

1. Operate the dip switches. When "ON" is indicated at the right side of a certain tested item, the item is OK.
 2. If the DATA value decreases when the bike is inclined to the right, or increases when it is inclined to the left the testing is OK (the data is indicated in the form of hexadecimal values). Make adjustment in a manner so that in the static condition the value shows 80H.
 3. If the data value increases when the accelerator/brake is applied and the value ranges between "00H" and "4H" when it is returned to its original position, then the item test is OK.
- o When the test is ended, push the TEST button.

(3) Output Test

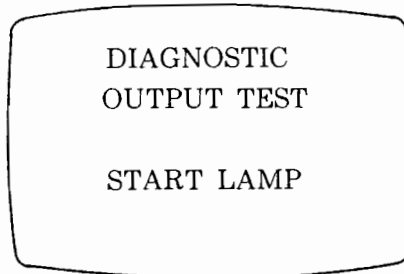

If the start LAMP lights up, it is functioning properly.
Push the TEST button when the testing has been completed.

(4) Sound Test

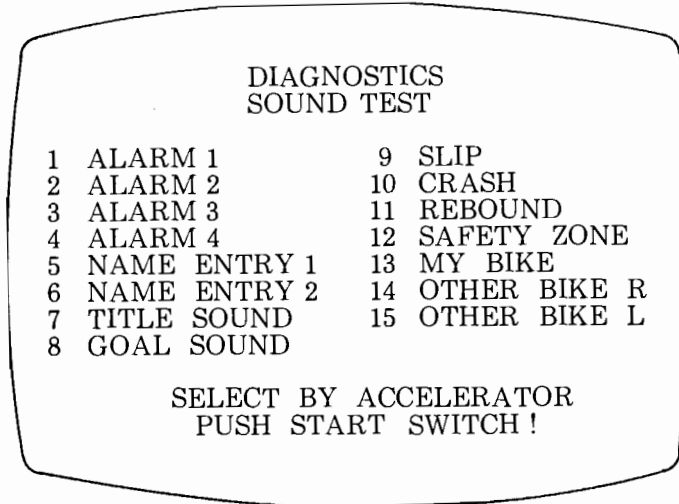

When the test has been completed, push the TEST button.

(5) C.R.T. TEST

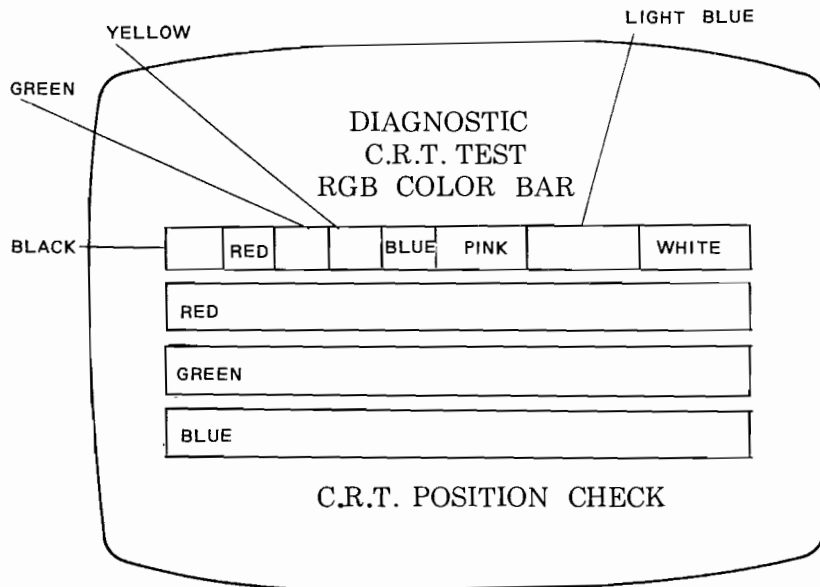

When the test has been completed, push the TEST button.

(6) DIP SWITCH ASSIGNMENTS

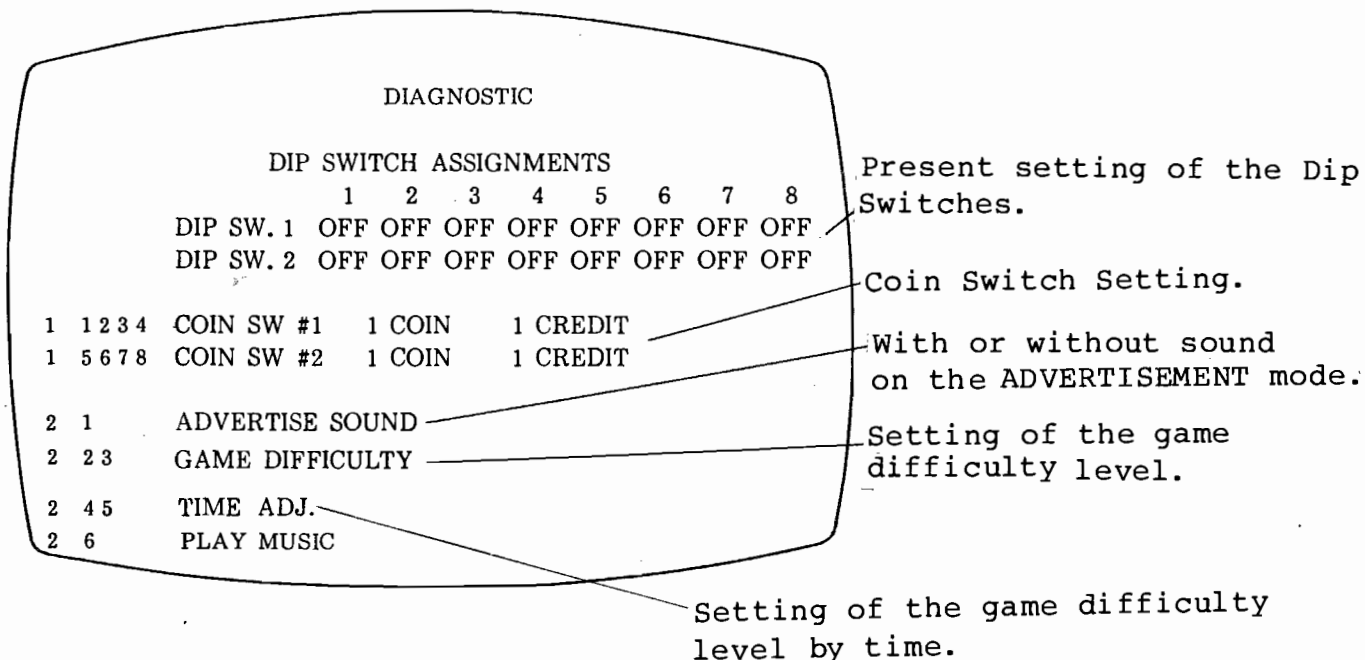

(7) Bookkeeping information

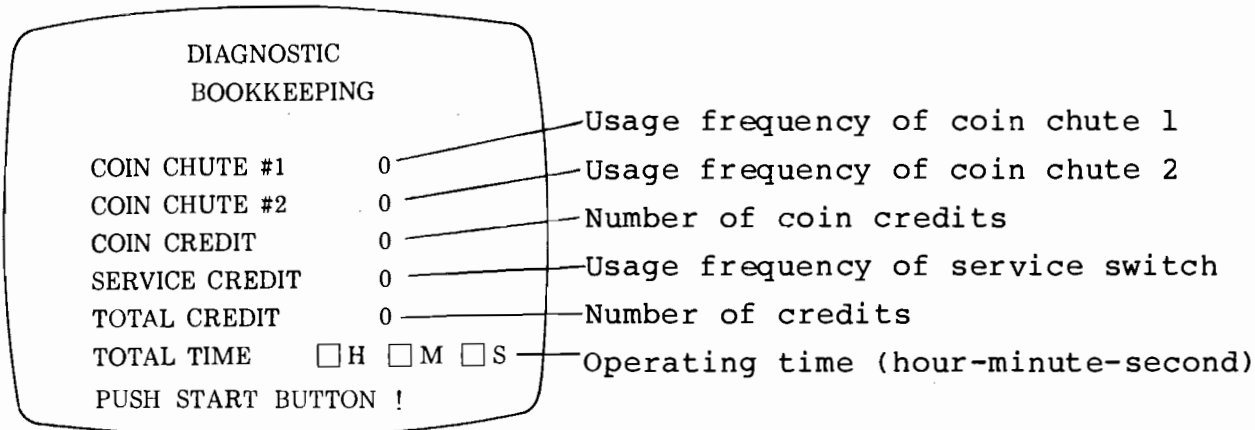

* Only the data that falls within the range of up to 999H 59M 59S can be memorized. The above screen indication is for testing. When the tests are finished, push the START button and the following will be shown:

| DIAGNOSTIC BOOKKEEPING | |
|---------------------------|--|
| NUMBER OF GAMES | 203 |
| AVE. SCORE | 7230 |
| TOP-SCORE | 9320 |
| LOW-SCORE | 4230 |
| ** GAME TIME ** | |
| TOTAL | <input type="checkbox"/> H <input type="checkbox"/> M <input type="checkbox"/> S |
| AVERAGE | <input type="checkbox"/> H <input type="checkbox"/> M <input type="checkbox"/> S |
| LONGEST | <input type="checkbox"/> H <input type="checkbox"/> M <input type="checkbox"/> S |
| PUSH START BUTTON! | |

Every time the TEST button is pressed, the bookkeeping test display is repeated. When the test is finished, push the TEST button to end the test (in the case of "INDIVIDUAL", however, the test mode returns to Fig. 1 first).

NOTE: o Once the power source is turned OFF, all the bookkeeping data will be completely cleared.

o If any data exceeds the bookkeeping function's capacity, "OVERFLOW" will be indicated on the screen and result in the stoppage of said function. At this time, turn the power OFF and turn it back ON again for reuse.

(8) EXIT

In the state as shown in Fig. 1, operate the handle to bring the arrow to EXIT and push the TEST button. The self-testing will then end and return to the ADVERTISING mode.

12. REMOVING THE HANDLE COVER

1. When adjusting the ACCELERATOR, BRAKE, etc., remove the HANDLE COVER by using the following procedure:

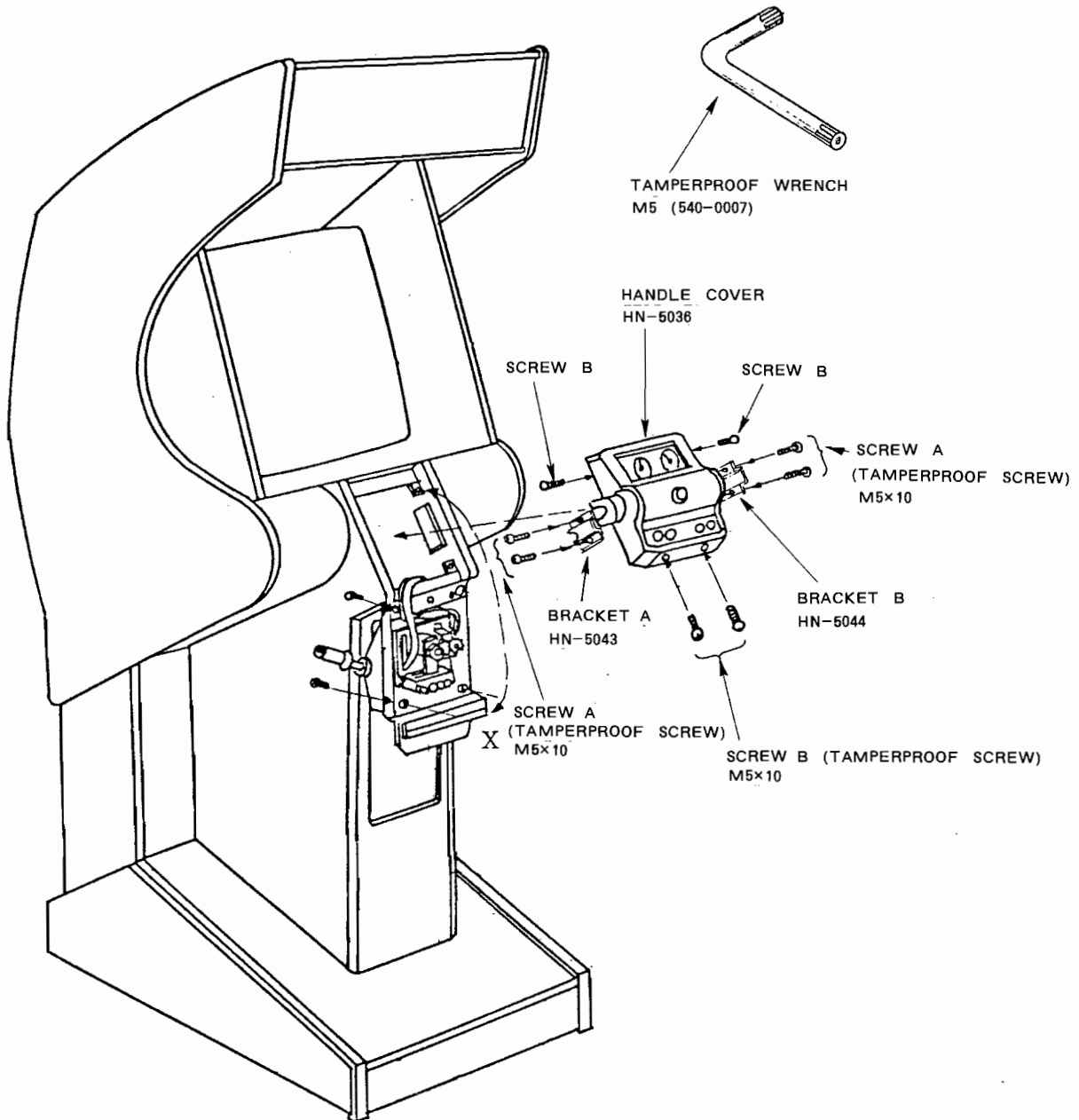

DISASSEMBLING PROCEDURE

- ① Remove 4 SCREWS A which fasten BRACKET A and BRACKET B by using the TAMPERPROOF WRENCH (M5).
- ② Remove 4 SCREWS B which fasten the HANDLE COVER by using the TAMPERPROOF WRENCH (M5).
- ③ The HANDLE COVER can be detached from the HANDLE UNIT in accordance with the above procedures ① and ②. It is completely removable from the MAIN CABINET by pulling out the CONNECTOR (orange, 4P).

13. REMOVING THE HANDLE UNIT

- o When adjusting the ACCELERATOR VOLUME and BRAKE VOLUME, remove the HANDLE UNIT by using the following procedure:

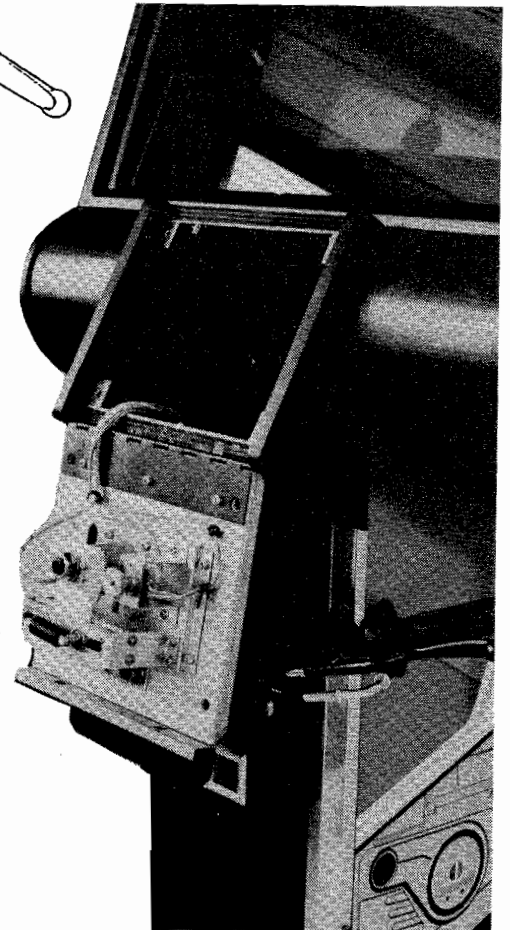
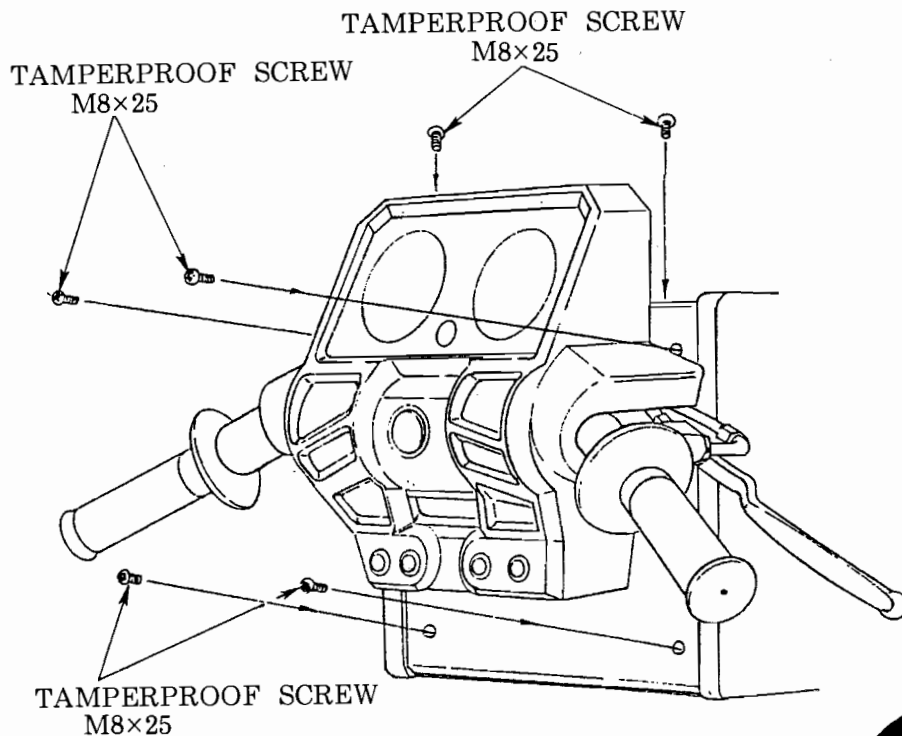

DISASSEMBLING PROCEDURE

For the adjustment of the ACCELERATOR/BRAKE volumes, take off the 6 TAMPERPROOF SCREWS by using the TAMPERPROOF WRENCH and remove the HANDLE UNIT as shown above. Refer to the separate item, ADJUSTING THE ACCELERATOR/BRAKE VOLUMES.

14. REMOVING THE WINDOW MASK

- o When cleaning the monitor screen, the back of the WINDOW GLASS, the PLASTIC PLATE, etc., remove the WINDOW MASK from the CABINET by using the following procedure:

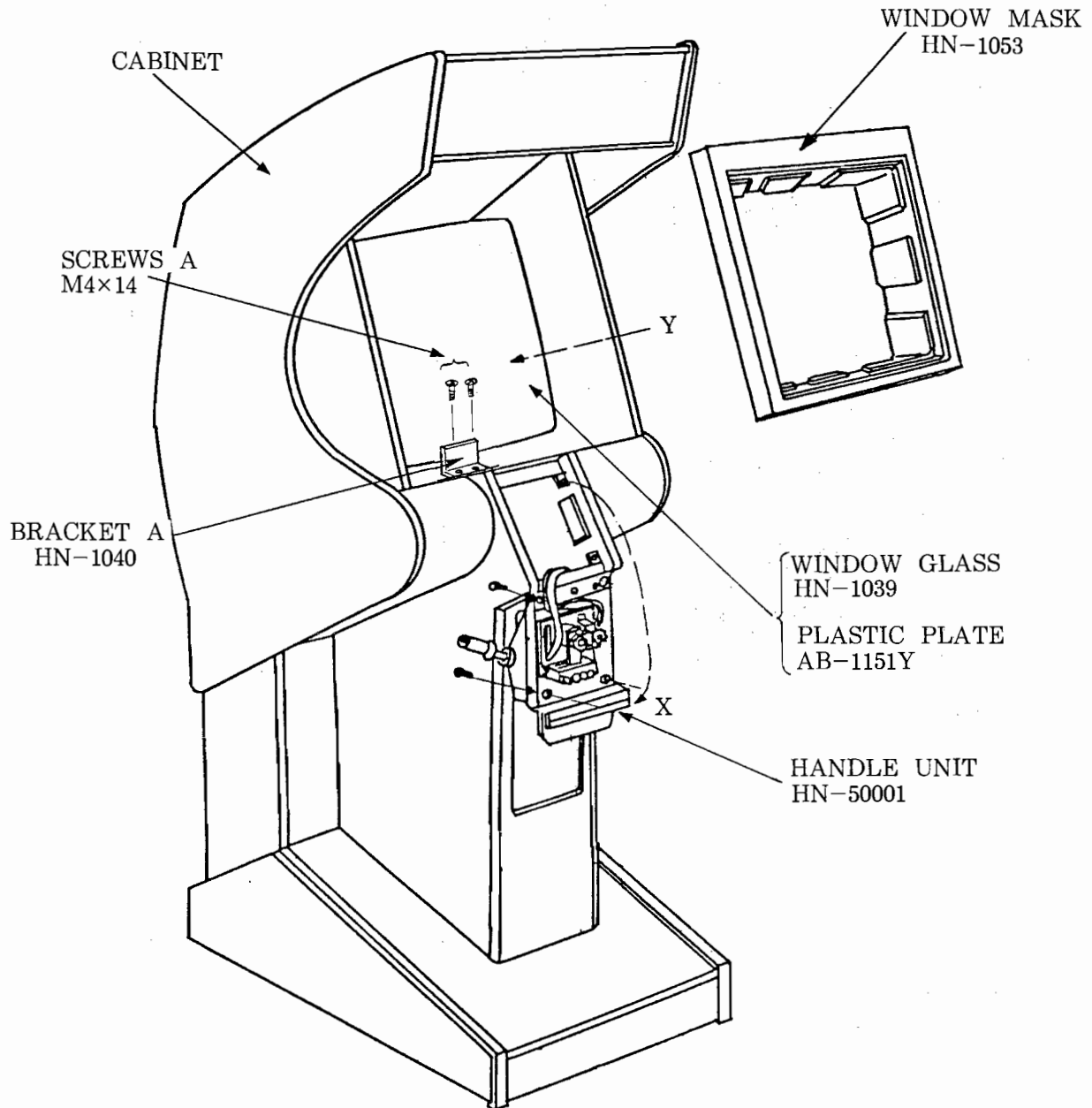

PROCEDURE

- ① Refer to REMOVING THE HANDLE UNIT (page 21).
The HANDLE UNIT can be opened in the direction of X and then the WINDOW MASK removed in the direction of Y.
- ② Remove BRACKET A which fastens the WINDOW GLASS by taking off 2 SCREWS A. In the above procedure, the WINDOW GLASS and the PLASTIC PLATE can be removed for cleaning from the CABINET.

15. REPLACING THE ACCELERATOR / BRAKE VOLUME CONTROLS

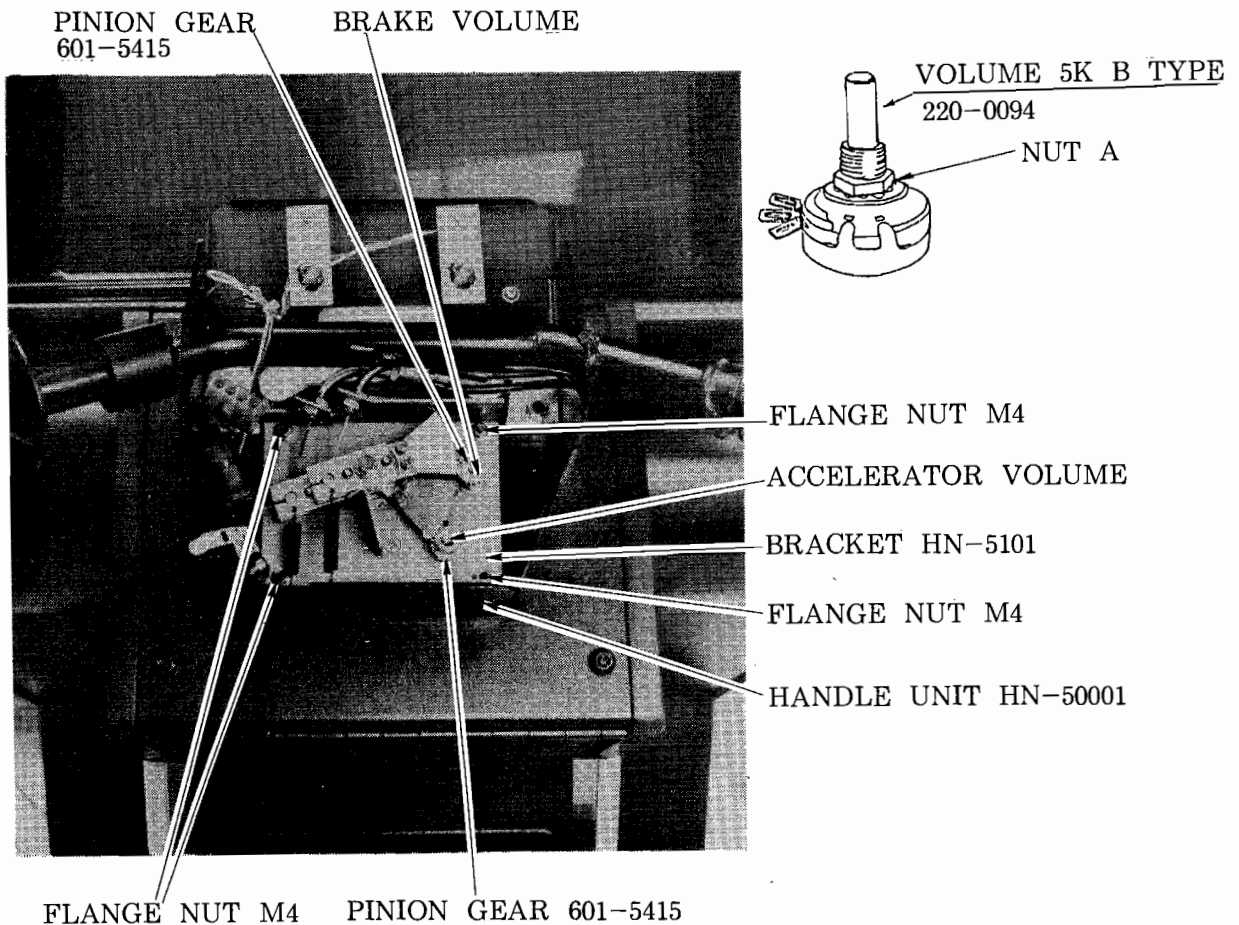

DISASSEMBLING PROCEDURE

1. To remove the BRACKET from the HANDLE UNIT, take off the 4 FLANGE NUTS which fasten the BRACKET.
2. To remove the PINION GEAR attached to the VOLUME SHAFT to be replaced, release the 2 SET SCREWS that fasten the PINION GEAR.
3. The VOLUME CONTROL can be removed from the BRACKET by taking off the VOLUME SHAFT'S NUT A.
4. After the replacement has been made, reassemble them in sequential order opposite from the above procedure.

16. REPLACING THE ACCELERATOR / BRAKE WIRES

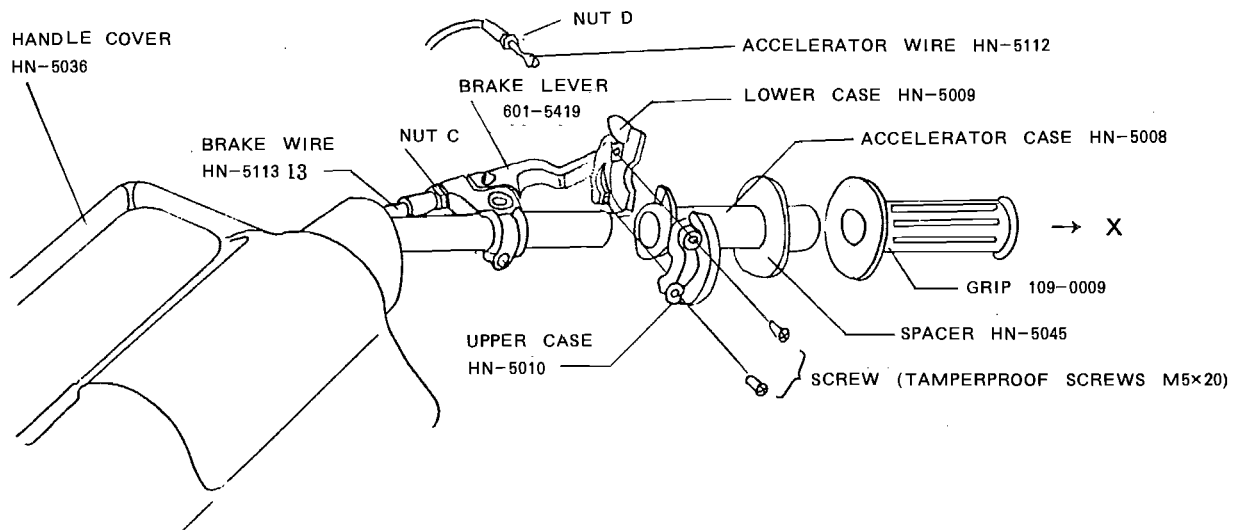
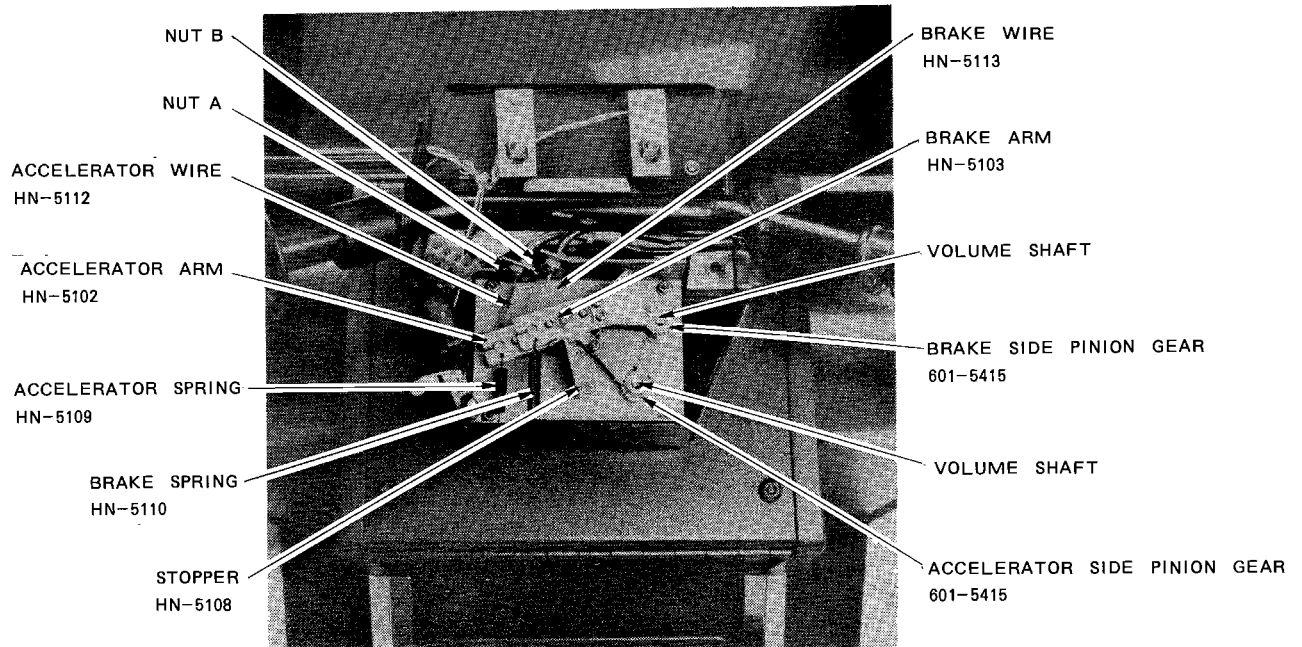

REPLACING THE ACCELERATOR WIRE

- ① Remove the HANDLE COVER (for the removal method, page 20.)
- ② Take off 2 TAMPERPROOF SCREWS A to disassemble the UPPER CASE and the LOWER CASE from the ACCELERATOR CASE.
- ③ In the above second illustration, the ACCELERATOR WIRE which is attached to the LOWER CASE can be removed by turning the LOWER CASE counterclockwise.
- ④ In the above first illustration, after removing the ACCELERATOR SPRING, release NUT A to take off the ACCELERATOR WIRE.

REPLACING THE BRAKE WIRE

- ① Remove the HANDLE COVER (for the removal method, page 20.)
- ② Release the BRAKE LEVER'S NUT C to remove the BRAKE WIRE.
- ③ Take off the BRAKE SPRING and NUT B to completely remove the BRAKE WIRE from the HANDLE UNIT.

17. PARTS LIST

① TOP ASSY HANG-ON (HN-00001) (D-1/2)

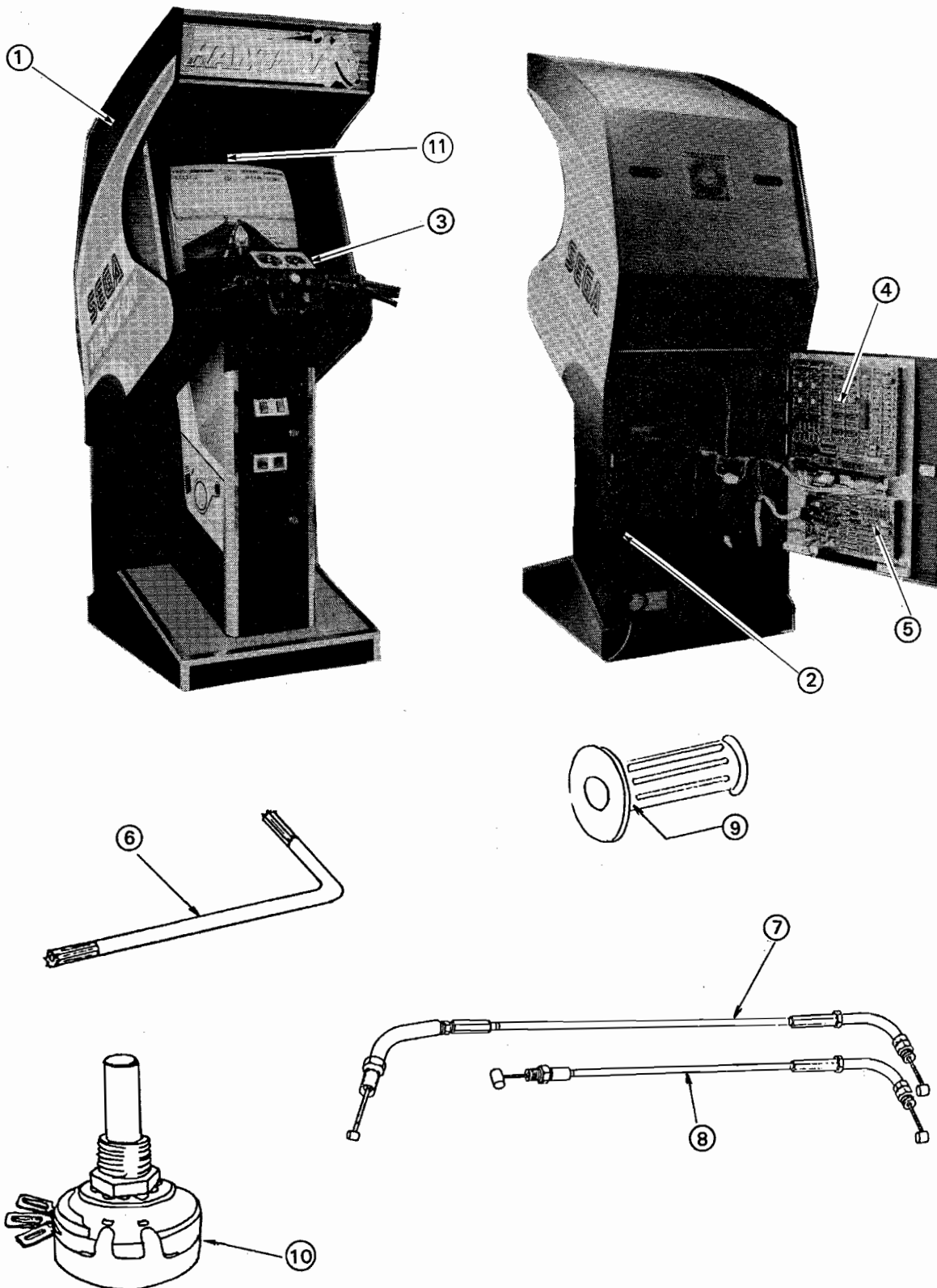

① TOP ASSY HANG-ON (HN-00001) (D-2/2)

| ITEM NO. | PART NO. | DESCRIPTION |
|----------|-------------|-----------------------------------|
| 1 | HN-10002 | ASSY CABINET |
| 2 | HN-40002 | ASSY POWER SUPPLY |
| 3 | HN-50001 | ASSY HANDLE |
| 4 | 834-5667-01 | ASSY GAME BOARD A |
| 5 | 834-5706-01 | ASSY GAME BOARD A |
| 6 | 540-0007 | WRENCH FOR TAMPERPROOF SCREW M5 |
| | 540-0015 | WRENCH FOR TAMPERPROOF SCREW M6 |
| | 540-0009 | WRENCH FOR TAMPERPROOF SCREW M8 |
| 7 | HN-5112 | ACCELERATOR WIRE S |
| 8 | HN-5113 | BRAKE WIRE S |
| 9 | 107-0009 | GRIP LEFT & ACCEL |
| 10 | 220-0094 | VOLUME CONTROL 5K Ω B TYPE |
| | 220-5130 | VOLUME CONTROL B-5K Ω |
| 11 | 422-0057 | PLAY INSTR SH |
| | 420-5247 | DISPLAY MANUAL 20" |

② ASSY CABINET (HN-10002) (D-1/3)

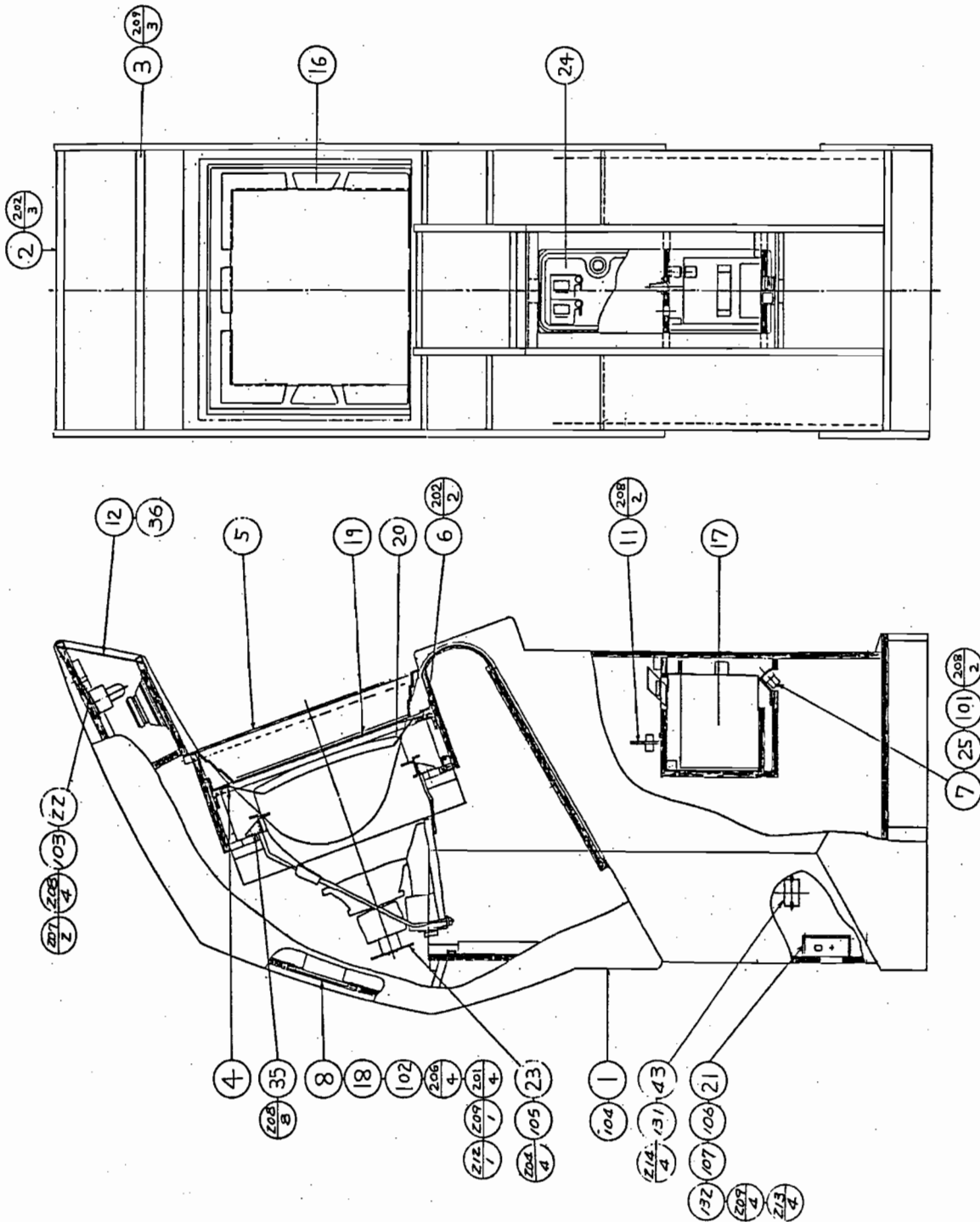

② ASSY CABINET (HN-10002) (D-2/3)

| ITEM NO. | PART NO. | DESCRIPTION |
|----------|-------------|---------------------------------|
| 1 | HN-1057 | ASSY SUB-CAB |
| 2 | HN-1036 | ORNAMENT FRAME TOP |
| 3 | HN-1037 | ORNAMENT FRAME LOWER |
| 4 | HN-1038 | MASK BOARD |
| 5 | HN-1039 | WINDOW GLASS |
| 6 | HN-1040 | HOLDER BRKT |
| 7 | HN-1056 | METER BRKT |
| 8 | HN-1042 | FAN BRKT |
| 11 | HN-1045 | SW UNIT |
| 12 | HN-1063 | BILLBOARD PLATE |
| 16 | HN-1053 | WINDOW MASK |
| 17 | HN-1055 | CASH BOX |
| 18 | MO-1051X | GUARD PLATE |
| 19 | AB-1151Y | TV MASK GRAY SMOKE |
| 20 | AB-1206 | TV MASK T8 20 |
| 21 | MO-1215Y | COVER |
| 22 | VE-1036 | FL BRKT |
| 23 | 200-5044 | ASSY CLR DSPL 20 TYPE |
| 24 | 109-0045 | KEY HOLDER |
| 25 | 80931 | STICKER COIN METOR |
| 26 | SGB-3637-2 | WIRE HARN FAN MOTER |
| 27 | SGB-3637-3 | WIRE HARN FL 15W |
| 28 | SGB-3637-4 | WIRE HARN EXT AC 100V |
| 29 | SGB-3637-8 | WIRE HARN AUDIO |
| 30 | SGB-3637-9 | WIRE HARN RGB |
| 31 | SGB-3637-10 | WIRE HARN EXT 50P |
| 32 | SGB-3637-12 | WIRE HARN COIN MTR |
| 33 | SGB-3637-17 | WIRE HARN EARTH |
| 34 | SGB-3637-18 | WIRE HARN AC IN |
| 35 | TY-1019 | BRKT TV |
| 36 | HN-1069 | RUBBER CUSHION |
| 37 | SGB-3637-21 | WIRE HARN EXT 12V |
| 38 | SGB-3637-20 | WIRE HARN EXT FL |
| 43 | 1050064 | BRKT MAIN SW |
| 101 | 220-5064 | MAG CNTR 6 DIG DC 5V |
| 102 | 260-0011 | AXIAL FLOW FAN AC 100V 50-60 Hz |
| 103 | 390-5108-01 | ASSY FL LIGHT 15W 50Hz PALUCK |
| | 390-5120-01 | ASSY FL LIGHT 15W 60Hz PALUCK |
| 104 | 280-0419 | HARNES LUG |
| 105 | 600-5133 | CABLE & CONN 300L |
| 106 | 280-0418 | BUSHING STRAIN RELIEF 8.3 |
| 107 | 280-0417 | TERMINAL BINDING POST BLACK |
| 108 | 209-0023 | CONN CLOSED END |
| 109 | 211-0167 | TERMINAL LUG ROUND ID 5 |
| 110 | 211-0043 | CONN PLUG AMP 2P WHITE |
| 111 | 211-0118 | CONN CAP AMP 3P RED |
| 112 | 211-0085 | CONN PLUG AMP 2P BROWN |
| 113 | 211-0073 | CONN PLUG AMP 4P WHITE |
| 114 | 211-0087 | CONN PLUG AMP 4P BROWN |
| 115 | 211-0102 | CONN PLUG AMP 4P YELLOW |
| 116 | 211-0044 | CONN CAP AMP 2P WHITE |
| 117 | 211-0080 | CONN CAP AMP 2P BROWN |
| 118 | 211-0117 | CONN CAP AMP 2P YELLOW |
| 119 | 211-0060 | CONN CAP AMP 3P WHITE |
| 120 | 211-0081 | CONN CAP AMP 3P BROWN |

② ASSY CABINET (HN-10002) (D-3/3)

| ITEM NO. | PART NO. | DESCRIPTION |
|----------|-------------|------------------------------------|
| 121 | 211-0072 | CONN CAP AMP 4P WHITE |
| 122 | 211-0082 | CONN CAP AMP 4P BROWN |
| 123 | 211-0084 | CONN CAP AMP 9P BROWN |
| 124 | 211-0065 | CONN CAP AMP 9P WHITE |
| 125 | 211-5105 | CONN FEM 50P |
| 126 | 211-5034 | CONN FEM 6P |
| 127 | 211-0041 | CONN PIN AMP |
| 128 | 211-0042 | CONN SOCKET AMP |
| 129 | 211-0005 | CONN CRIMP LOCK |
| 130 | 211-5047 | CONTACT (AMP 172656-2) |
| 131 | 509-0039 | SW PB TYPE |
| 132 | 600-0110 | CABLE & PLUG ASSY W/EARTH (USA) |
| | 600-5007 | CABLE & PLUG ASSY W/EARTH (EUROPE) |
| 201 | 000-0310-FS | M SCR PH W/FS M3×10 |
| 202 | 000-0414 -S | M SCR PH W/S M4×14 |
| 203 | 000-0510-S | M SCR PH W/S M5×10 |
| 204 | 000-0516-FS | M SCR PH W/FS M5×16 |
| 206 | 008-0416 | TMP PRF SCR TH M4×16 |
| 207 | 010-0406-F | S-TITE SCR PH W/F M4×6 |
| 208 | 005-3513 | W SCR RH 3.5×13 |
| 209 | 051-0004 | FLG NUT M4 |
| 212 | 000-0412 | M SCR PH M4×12 |
| 213 | 031-0425-B | CRG BLT BLK M4×25 |
| 214 | 005-3113-F | W SCR RH W/F 3.1×13 |

③ ASSY SUBCABINET (HN-1057) (D-3/3)

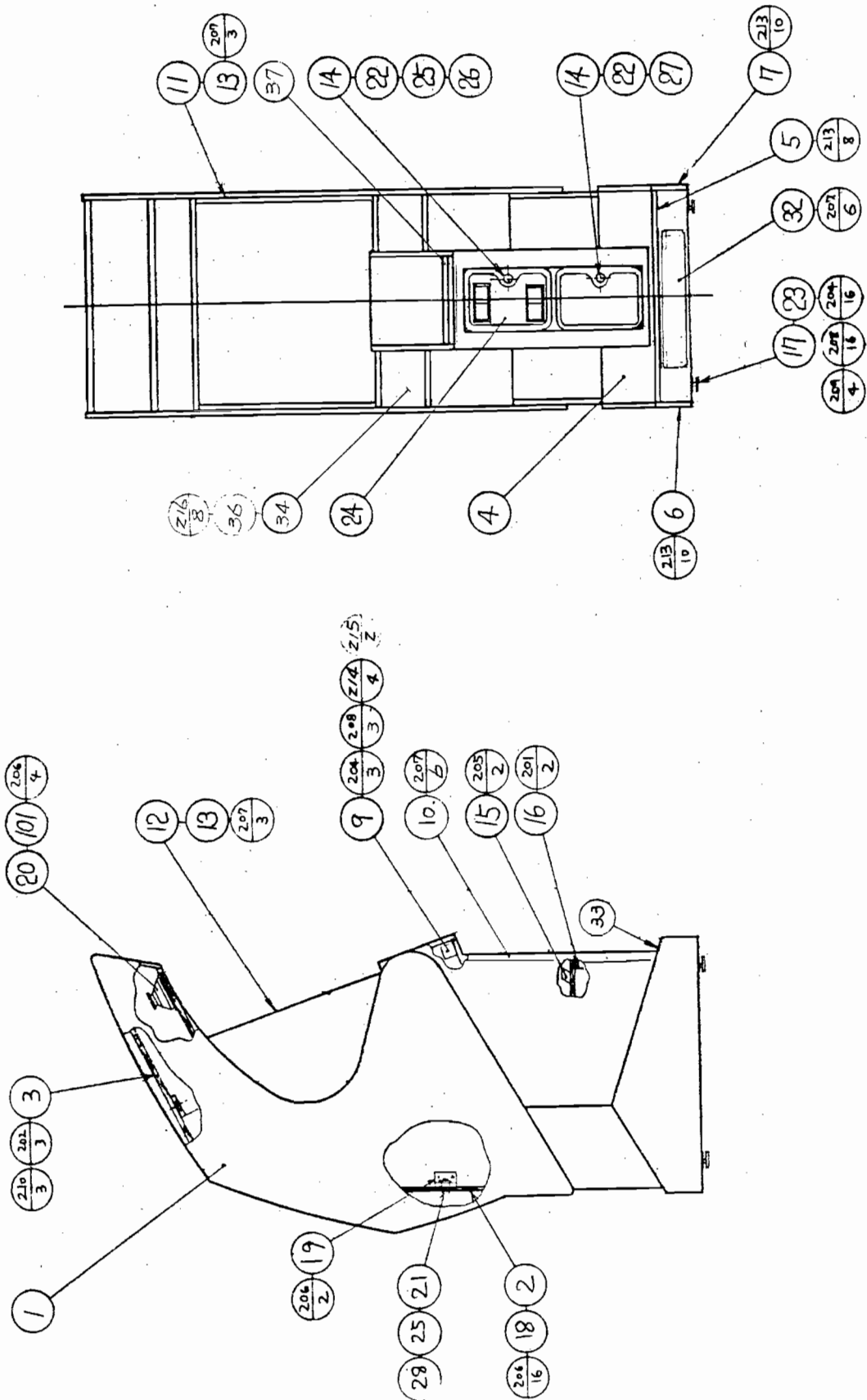

③ ASSY SUBCABINET (HN-1057) (D-2/3)

| ITEM NO. | PART NO. | DESCRIPTION |
|----------|-------------|---|
| 1 | HN-1058 | WOODEN CABINET |
| 2 | HN-1024 | BACK DOOR |
| 3 | HN-1025 | LID BOARD |
| 4 | HN-1026 | FLOOR MAT |
| 5 | HN-1027 | CORNER PROTECTOR A |
| 6 | HN-1028 | CORNER PROTECTOR B |
| 7 | HN-1029 | CORNER PROTECTOR C |
| 9 | HN-1031 | HANDLE UNIT BRACKET |
| 10 | HN-1061 | CORNER SASH |
| 11 | HN-1033 | ORNAMENT PROTECTOR A |
| 12 | HN-1034 | ORNAMENT PROTECTOR B |
| 13 | HN-1035 | SPACER |
| 14 | HN-1050 | SPACER RING |
| 15 | HN-1051 | LOWER COIN CHUTE |
| 16 | HN-1052 | LOCK BRKT |
| 17 | TA-1079X | LEG ADJUSTER BRKT |
| 18 | TA-1010 | HINGE 148 |
| 19 | SH-2061X | STOPPER |
| 20 | AN-1107 | GUARD PLATE |
| 21 | DP-1148X | LKG TNG |
| 22 | DP-1167 | TNG LKG |
| 23 | 601-0455 | LEG ADJUSTER |
| 24 | 222-5128-01 | ASSY COIN CHUTE 25 ϕ TWIN |
| | 222-5128-03 | ASSY COIN CHUTE 25 ϕ \times 2 TWIN |
| | 222-5128-04 | ASSY COIN CHUTE 1DM \times 2 5DM |
| 25 | 220-5044-01 | MAGNETIC LOCK W/O KEY |
| 26 | 220-5045-01 | KEY MASTER FOR 220-5044-01 |
| 27 | 220-5046 | MAGNETIC LOCK W/KEYS |
| 28 | 117-0062 | PLATE LOCK RETAINER |
| 29 | SGB-3637-5 | WIRE HARN SP RIGHT (MFG) |
| | SGB-3637-6 | WIRE HARN SP LEFT (MFG) |
| 31 | SGB-3637-11 | WIRE HARN COIN SW (MFG) |
| 32 | HN-1059 | LID PLATE |
| 33 | HN-1060 | FLOOR MAT FRONT |
| 34 | HN-1062 | ORNAMENT PLATE A |
| 36 | HN-1067 | HOLDER |
| 37 | HN-5035 | HINGE 246 |
| 38 | HN-1071 | BAFFLE BOARD |
| 39 | HN-1070 | SPACER BOARD |
| 101 | 130-5001 | SPEAKER 80HM ϕ 120 |
| 102 | 211-0094 | CONN PLUG AMP 2P RED |
| 103 | 211-0095 | CONN PLUG AMP 2P ORANGE |
| 104 | 211-0073 | CONN PLUG AMP 4P WHITE |
| 105 | 211-0041 | CONN PIN AMP |
| 106 | 280-5015 | FASTON RCPT 187 |
| 107 | 280-5016 | FASTON RCPT 205 |
| 201 | 000-0416-5 | M SCR PH W/S M4 \times 16 |
| 202 | 000-0430 | M SCR PH W/S M4 \times 30 |
| 204 | 031-0525-B | CRG BLT-BLK |
| 205 | 005-3113 | W SCR RH 3.1 \times 13 |

③ ASSY SUBCABINET (HN-1057) (D-1/3)

| ITEM NO. | PART NO. | DESCRIPTION |
|----------|------------|----------------------------|
| 206 | 005-3516-F | W SCR RH W/F 3.5×16 |
| 207 | 051-0004 | FLG NUT M4 |
| 208 | 051-0005 | FLG NUT |
| 209 | 059-0007 | HEX NUT 3/8-16 |
| 210 | 060-0004 | FLT WSHR M4 |
| 213 | 046-0001 | SCR NAIL TH H STNLS 1.5×16 |
| 214 | 005-3516 | W SCR RH 3.5×16 |
| 215 | 000-0516-5 | M SCR PH W/S M5×16 |
| 216 | 008-0416 | TMP PRF SCR TH M4×16 |

④ ASSY POWER SUPPLY EXPORT (HN-40002) (D-1/2)

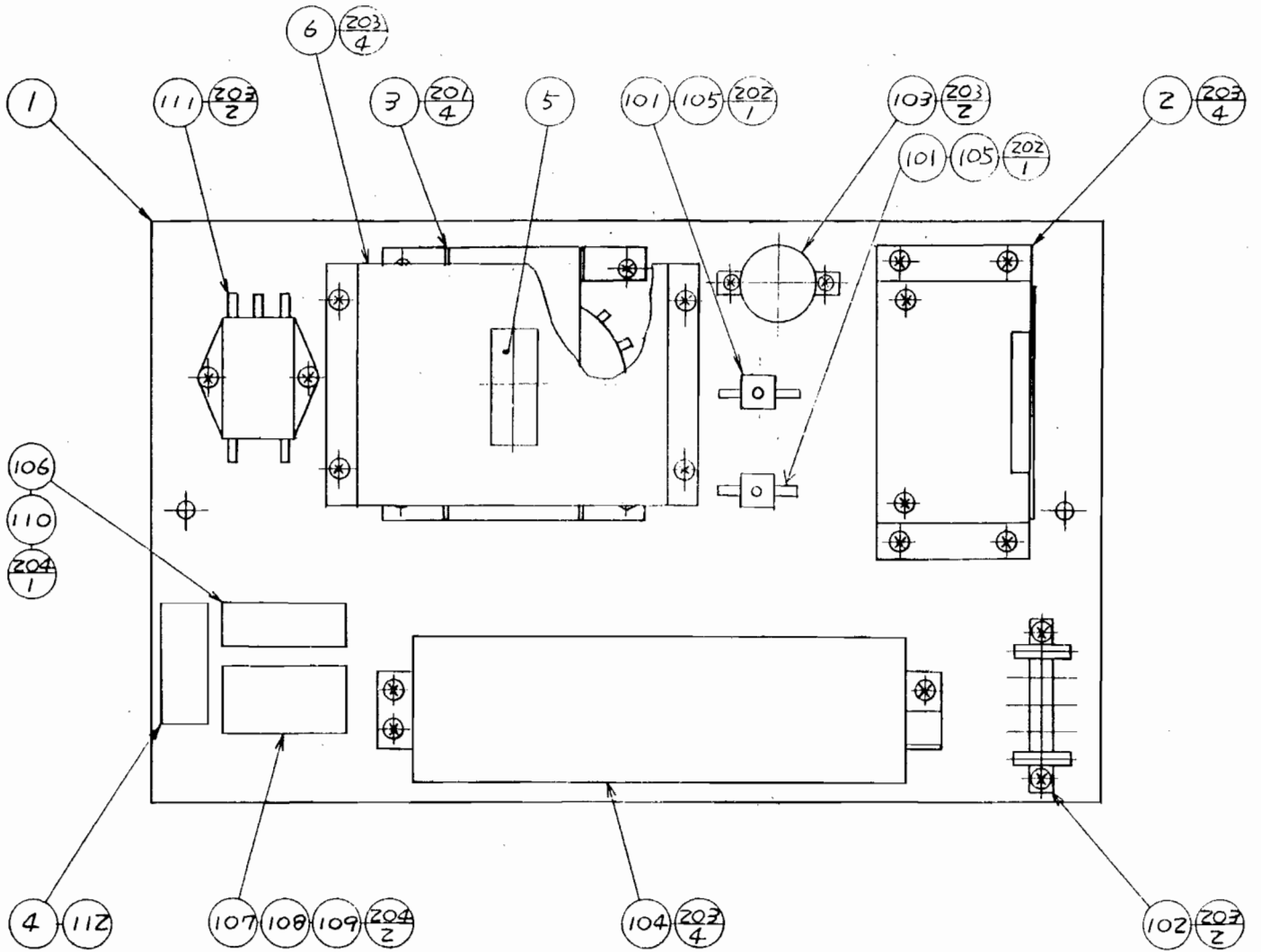

④ ASSY POWER SUPPLY EXPORT (HN-40002) (D-2/2)

| ITEM NO. | PART NO. | DESCRIPTION |
|----------|-------------|--------------------------------|
| 1 | HN-4004 | BASE |
| 2 | GR-4600 | PWR AMP DC 39V 15W |
| 3 | 560-5068 | PWR XFMP 90V-240V 10V 24V 100V |
| 4 | 421-6071 | FUSE INSTR |
| 5 | 421-6092 | FUSE INSTR |
| | 81319 | STICKER 120V |
| | 80666 | STICKER 200V |
| | 80556 | STICKER 220V |
| | 80595 | STICKER 230V |
| | 80309 | STICKER 240V |
| 6 | HN-4003 | COVER |
| 7 | SGB-3636-1 | WIRE HARN PWR SPLY |
| | SGB-3637-1 | WIRE HARN PWR SPLY |
| 101 | 117-0068 | TERMINAL PLATE IL3P |
| 102 | 211-0174 | TERMINAL PLATE 5P |
| 103 | 150-0173 | CAP E 4700MF 50V C-TYPE |
| 104 | 400-5035 | SW REG 90V-240V 5V 10A |
| 105 | 481-0065 | DIODE BRIDGE S2VB10 |
| 106 | 514-0045 | FU HLDR W/COVER |
| 107 | 514-0064 | FU HLDR 2P W/COVER |
| 108 | 514-0036 | FU 3A 6.4×30MM |
| | 514-0036 | FU SA 6.4×30MM |
| 109 | 514-0040 | FU 4A 6.4×30MM |
| 110 | 514-0034 | FU 5A 6.4×30MM |
| 111 | 601-0429 | NOISE FLTR AC250V |
| 112 | 601-0769 | STAPLE MAX #3 |
| 113 | 280-0419 | HARNES LUG |
| 114 | 211-0167 | TERMINAL LUG ROUND ID5 |
| 115 | 211-0097 | CONN PLUG AMP 3P RED |
| 116 | 211-0080 | CONN CAP AMP 2P BROWN |
| 117 | 211-0115 | CONN CAP AMP 2P RED |
| 118 | 211-0116 | CONN CAP AMP 2P ORANGE |
| 119 | 211-0072 | CONN CAP AMP 4P WHITE |
| 120 | 211-0123 | CONN CAP AMP 4P YELLOW |
| 121 | 211-0157 | CONN FEM 3P |
| 122 | 211-0158 | CONN FEM 6P |
| 123 | 211-5101 | CONN FEM 10P |
| 124 | 211-0041 | CONN PIN AMP |
| 125 | 211-0042 | CONN SOCKET AMP |
| 126 | 211-0005 | CONN CRIMP LOCK |
| 127 | 211-5047 | CONTACT (AMP 172656-2) |
| 128 | 211-0044 | CONN CAP AMP 2P WHITE |
| 201 | 000-0414-FS | M SCR PH W/FS M4×14 |
| 202 | 005-3110 | W SCR RH 3.1×10 |
| 203 | 005-3113-F | W SCR RH W/F 3.1×13 |
| 204 | 005-3120 | W SCR RH 3.1×20 |

⑤ ASSY HANDLE (HN-50001) (D-1/3)

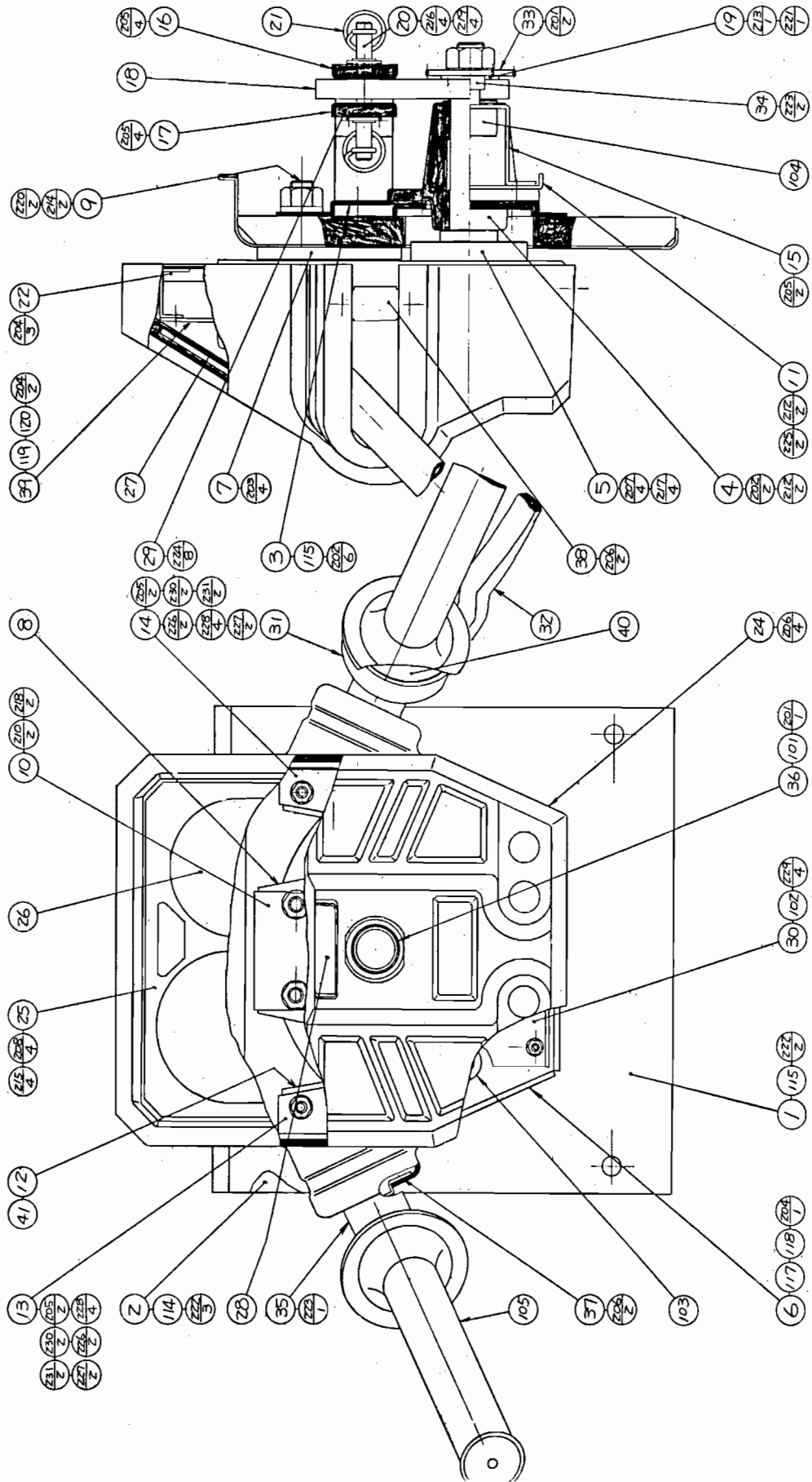

⑤ ASSY HANDLE (HN-50001) (D-2/3)

| ITEM NO. | PART NO. | DESCRIPTION |
|----------|-------------|-------------------------------------|
| 1 | HN-5013X | FRONT PANEL |
| 2 | HN-5014 | BASE |
| 3 | HN-5015 | HANDLE BRACKET |
| 4 | TB-2004X | HOUSING |
| 5 | HN-5017 | HANDLE SHAFT |
| 6 | HN-5018X | HANDLE BASE |
| 7 | HN-5019 | SLIDE PLATE A |
| 8 | HN-5020 | SLIDE PLATE B |
| 9 | HN-5021 | SLIDE SHAFT |
| 10 | HN-5022 | SLIDE HOLDER |
| 11 | HN-5023 | VR BRACKET BASE |
| 12 | HN-5024X | BUMPER |
| 13 | HN-5025X | BUMPER HOLDER A |
| 14 | HN-5026X | BUMPER HOLDER B |
| 15 | HN-5027 | VR BRACKET |
| 16 | HN-5028 | GUIDE BRACKET UPPER |
| 17 | HN-5029 | GUIDE BRACKET LOWER |
| 18 | HN-5030 | CAM |
| 19 | HN-5031 | GEAR BRACKET |
| 20 | HN-5032X | SHAFT |
| 21 | HN-5033X | EXTENSION SPRING |
| 22 | HN-5034 | REAR LID |
| 24 | HN-5036 | MECHANISM COVER |
| 25 | HN-5037 | PANEL |
| 26 | HN-5038 | METER PLATE F |
| 27 | HN-5039 | METER PLATE R |
| 28 | 421-6103 | STICKER START |
| 29 | HN-5040 | GUIDE PLATE |
| 30 | HN-5111 | ASSY CONTROL |
| | SGB-3636-13 | WIRE HARN VR |
| | SGB-3636-15 | WIRE HARN START |
| | SGB-3636-16 | WIRE HARN EXT CONT |
| 31 | 601-5418 | ASSY ACCELERATOR CASE |
| 32 | 601-5419 | ASSY LEVER |
| 33 | 601-5423 | GEAR 1/6 |
| 34 | 601-5424 | GEAR 30 |
| | SGB-3636-21 | WIRE HARN LAMP |
| 35 | HN-5041 | SPACER |
| 36 | HN-5042 | STOPPER RING |
| 37 | HN-5043X | COVER A |
| 38 | HN-5044X | COVER B |
| 39 | TB-2007 | LAMP HOLDER BOARD |
| 40 | HN-5045 | SPACER |
| 41 | HN-5046 | SPACER TUBE |
| 101 | 509-5050 | PUSH BUTTON SWITCH 1T YELLOW W/LAMP |
| 102 | 310-5009 | INST SPIRAL TUBE ID ϕ 9 |
| 103 | 280-5066 | RUBBER GROMMET |
| 104 | 220-0094 | VOL CONT 5K Ω B TYPE |
| | 220-5130 | VOL CONT B-5K OHM |
| 105 | 107-0009 | GRIP LEFT & ACCELERATOR |

⑤ ASSY HANDLE (HN-50001) (D-3/3)

| ITEM NO. | PART NO. | DESCRIPTION |
|----------|-------------|--------------------------------|
| 106 | 211-0059 | CONN PLUG AMP 3P WHITE |
| 107 | 211-0101 | CONN PLUG AMP 4P ORANGE |
| 108 | 211-0064 | CONN PLUG AMP 9P WHITE |
| 109 | 211-0121 | CONN CAP AMP 4P RED |
| 110 | 211-0122 | CONN CAP AMP 4P ORANGE |
| 111 | 211-0041 | CONN PIN AMP |
| 112 | 211-0042 | CONN SOCKET AMP |
| 113 | 280-0472 | FASTON RCPT 110 |
| 114 | 280-0419 | HARNESS LUG |
| 115 | 601-5003 | FREE BUSH |
| 116 | 211-0043 | CONN PLUG AMP 2P WHITE |
| 117 | 280-0132 | CLAMP CORD PLASTIC ID 10mm |
| 118 | 280-5008 | CORD CLAMP ϕ 15 |
| 119 | 214-0081 | WEDGE BASE SOCKET ASSY |
| 120 | 390-0116 | LAMP WEDGE BASE TYPE 14V 0.24A |
| 201 | 000-0406-S | M SCR PH M4x6 |
| 202 | 000-0514 | M SCR PH W/S M5x14 |
| 203 | 006-3520 | W SCR FH 3.5x20 |
| 204 | 010-0308-F | S-TITE SCR PH W/F M3x8 |
| 205 | 010-0408-F | S-TITE SCR PH W/F M4x8 |
| 206 | 008-0510 | TMP PRF SCR TH M5x10 |
| 207 | 030-0612 | HEX BLT M6x12 |
| 208 | 050-0004 | HEX NUT M4 |
| 210 | 050-0008 | HEX NUT M8 |
| 212 | 051-0005 | FLG NUT M5 |
| 213 | 059-0016 | HEX NUT M14 |
| 214 | 059-0017 | HEX NUT M12 P=1.75 |
| 215 | 060-0004 | FLT WSHR M4 |
| 216 | 060-0008 | FLT WSHR M8 |
| 217 | 061-0006 | SPR WSHR M6 |
| 218 | 061-0008 | SPR WSHR M8 |
| 219 | 065-0006 | E RING 6mm |
| 220 | 069-0016 | SPR WSHR BLK M12 |
| 221 | 069-0019 | SPR WSHR M14 |
| 222 | 005-3113-F | W SCR RH W/F 3.1x13 |
| 223 | 028-0014 | SET SCR HEX SKT CP UNBR M4x4 |
| 224 | 001-0410 | M SCR FH M4x10 |
| 225 | 000-0516-S | M SCR PH W/S M5x16 |
| 226 | 001-0512 | M SCR FH M5x12 |
| 227 | 029-0043 | M SCR FH M6x35 |
| 228 | 060-0006 | FLT WASHER M6 |
| 229 | 000-0410-FS | M SCREW PH W/FS M4x10 |
| 230 | 054-0005 | U NUT M5 |
| 231 | 054-0006 | U NUT M6 |

⑥ ASSY CONTROL (HN-5111) (D-1/2)

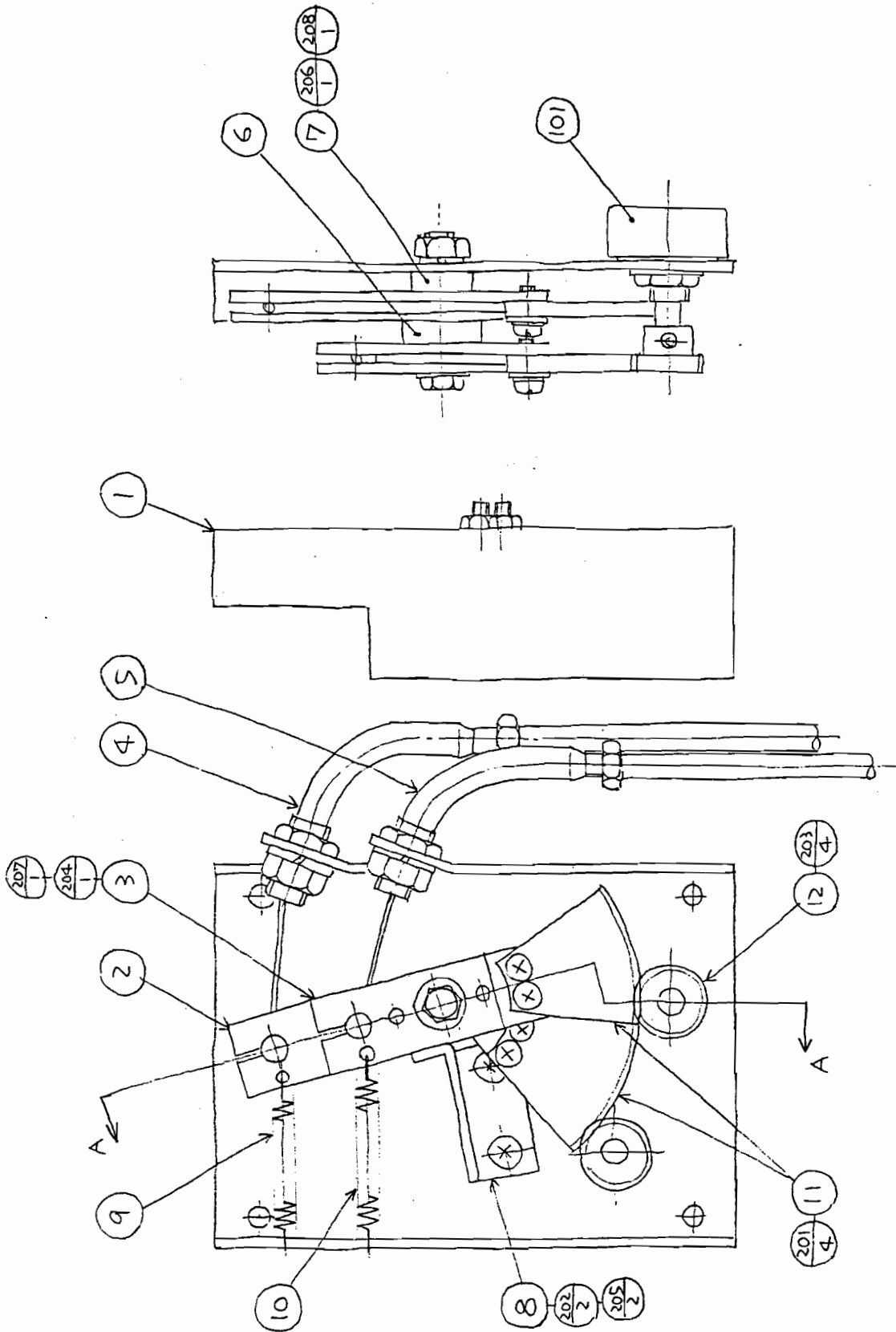

⑥ ASSY CONTROL (HN-5111) (D-2/2)

| ITEM NO. | PART NO. | DESCRIPTION |
|----------|-------------|------------------------------|
| 1 | HN-5101 | BRACKET |
| 2 | HN-5102 | LEVER LONG |
| 3 | HN-5103 | LEVER SHORT |
| 4 | HN-5112 | ACCELERATOR WIRE S |
| 5 | HN-5113 | BRAKE WIRE S |
| 6 | HN-5106 | SPACER |
| 7 | HN-5107 | STUD |
| 8 | HN-5108 | STOPPER |
| 9 | HN-5109 | EXT SPRING ACCEL |
| 10 | HN-5110 | EXT SPRING BRAKE |
| 11 | 601-5251 | GEAR 1/8 |
| 12 | 601-5415 | GEAR 20 |
| | SGB-3636-14 | WIRE HARN CONT |
| 101 | 220-0094 | VOL CONT 5KΩ B TYPE |
| | 220-5130 | VOL CONT B-5K OHM |
| 102 | 211-0100 | CONN PLUG 4P RED |
| 103 | 211-0041 | CONN PIN AMP |
| 201 | 000-0408-FS | M SCR PH W/FS M4×8 |
| 202 | 001-0410 | M SCR FH M4×10 |
| 203 | 028-0014 | SET SCR HEX SKT CP UNBR M4×4 |
| 204 | 030-0508 | HEX BLT M5×8 |
| 205 | 050-0004 | HEX NUT M4 |
| 206 | 050-0006 | HEX NUT M6 |
| 207 | 060-0005 | FLT WSHR M5 |
| 208 | 061-0006 | SPR WSHR M6 |

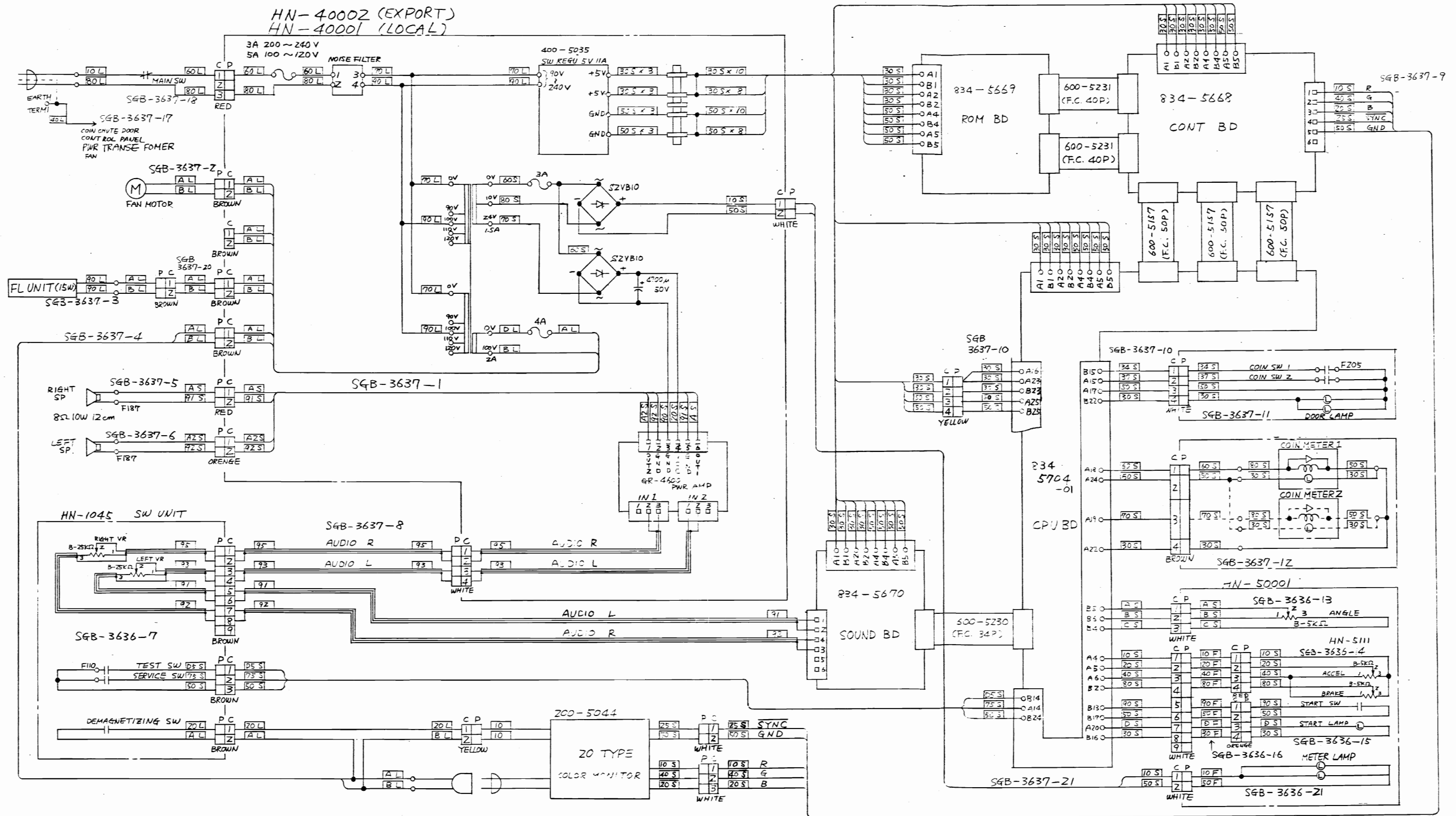

18. SCHEMATIC DIAGRAM

SEGA ENTERPRISES, LTD.
No. 2 -12 Haneda 1-Chome
Ohta-Ku, Tokyo, Japan 144

- Tel. : (03) 743 - 7438
- FAX : (03) 743 - 5539
- TLX : J22357 SEGASTAR

© SEGA 1986

Printed in Japan